

PARTS CATALOGUE

YZ85'09 (5PAN) EUROPE,SOUTH AFRICA

YZ85LW (5SHN) EUROPE,SOUTH AFRICA

YZ85
YZ85Y/YZ85LW
PARTS CATALOGUE
©2008 by Yamaha Motor Co., Ltd.
1st edition, July 2008
All rights reserved.
Any reprinting or unauthorized use
without the written permission of
Yamaha Motor Co., Ltd.
is expressly prohibited.
Printed in Japan.

FOREWORD

This Parts Catalogue is related to the parts for the model(s) on the cover page. When you are ordering replacement parts, please refer to this Parts Catalogue and quote both part numbers and part names correctly.

1. Modifications or additions which have been made after the issue of the Parts Catalogue will be announced in the Parts News.

It is advisable that you make the necessary corrections to the Parts Catalogue according to the Parts News.

2. Abbreviations

The following abbreviations are used in this Parts Catalogue.

“UR” Use specified parts number.

“UN” Use as many as needed.

“AP” Alternate Parts

“LM” Locally Made (Parts need to be ordered locally)

“F#” Frame No. (Applicable machine No.)

“O/S” Over Size

3. The number of components for assembly

- Parts, which are to be supplied in an assembly, are listed with a dot (.) in front of the part name as shown below.
- The numeral appearing to the right of each component part indicates the quantity of parts for each assembly unit.

PART NO.	DESCRIPTION	Q'TY	REMARKS
2F5-83310-60	FRONT FLASHER LIGHT ASSY	2	
115-83311-60	.BULB (6V-18W)	1	

4. Applicable colours of graphics are represented in the “REMARKS” as shown below.

PART NO.	DESCRIPTION	Q'TY	REMARKS
2N4-24110-00-X5	FUEL TANK COMP.	2	MXR
3J1-24240-10	.GRAPHIC, FUEL TANK	1	FOR MXR

5. Note that the illustrations for reference in finding parts numbers are not to be used for assembling. When assembling, please use the applicable service manual.

6. The asterisk (*) before a reference number indicates modified items after the first edition.

MODEL LABEL

(1) A label called "Model Label" is affixed in the location as indicated in (3) below. When using this parts catalogue, please be sure to cross-reference the "model code – production code No." in the catalogue with the "model code – production code No." indicated on the Model Label affixed onto the product concerned.

(2) "Model Label" Indication

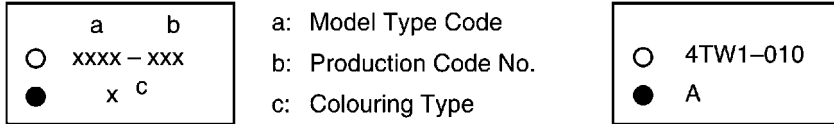

(3) Model Label Affixing Location

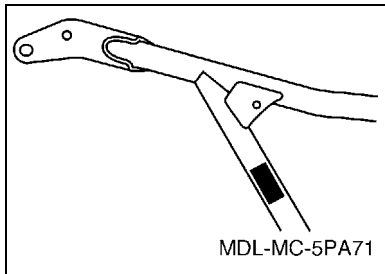

(4) Colouring Information

Model Code	Colouring Type Code	Colour Code	Colour Name	Abbreviation
5PAN	A	0583	DEEP PURPLISH BLUE SOLID E	DPBSE
5PAR	A	0583	DEEP PURPLISH BLUE SOLID E	DPBSE
5SHN	A	0583	DEEP PURPLISH BLUE SOLID E	DPBSE
5SHR	A	0583	DEEP PURPLISH BLUE SOLID E	DPBSE

(5) Model Code – Production Code Number of Model Listed in This Parts Catalogue

Model Code	Production Code No.	Country (destination)	Model Code	Production Code No.	Country (destination)	
5PAN	050	CANADA	5SHN	010	IRELAND	
	060	SOUTH AFRICA			NETHERLANDS	
		AUSTRIA			NORWAY	
		BELGIUM			PORTUGAL	
		DENMARK			SPAIN	
		FINLAND			SWEDEN	
		FRANCE			SWITZERLAND	
		GERMANY			UNITED KINGDOM	
		GREECE				
		IRELAND				
		NETHERLANDS				
		NORWAY				
		PORTUGAL				
		SPAIN				
		SWEDEN				
		SWITZERLAND				
		UNITED KINGDOM				
	5PAR	010	JAPAN			
	5SHN	010	AUSTRIA	5SHR	010	JAPAN
BELGIUM						
DENMARK						
FINLAND						
FRANCE						
GERMANY						
		GREECE				

CONTENTS

ENGINE

CYLINDER	1
CRANKSHAFT & PISTON	2
WATER PUMP	3
RADIATOR & HOSE	4
INTAKE	5
CARBURETOR	6
EXHAUST	8
CRANKCASE	9
CRANKCASE COVER 1	10
STARTER	11
CLUTCH	12
TRANSMISSION	13
SHIFT CAM & FORK	15
SHIFT SHAFT	16

CHASSIS

FRAME	17
FENDER	18
SIDE COVER	19
REAR ARM	20
REAR SUSPENSION	22
STEERING	24
FRONT FORK	25
FUEL TANK	28
SEAT	29
FRONT WHEEL	30
FRONT BRAKE CALIPER	31
REAR WHEEL	32
REAR BRAKE CALIPER	34
STEERING HANDLE & CABLE	35
FRONT MASTER CYLINDER	36
STAND & FOOTREST	37
REAR MASTER CYLINDER	38
GENERATOR	39
HANDLE SWITCH & LEVER	40
ELECTRICAL 1	41
ALTERNATE FOR CHASSIS	42
OPTIONAL PARTS 1	43

INDEX

NUMERICAL INDEX	44
-----------------------	----

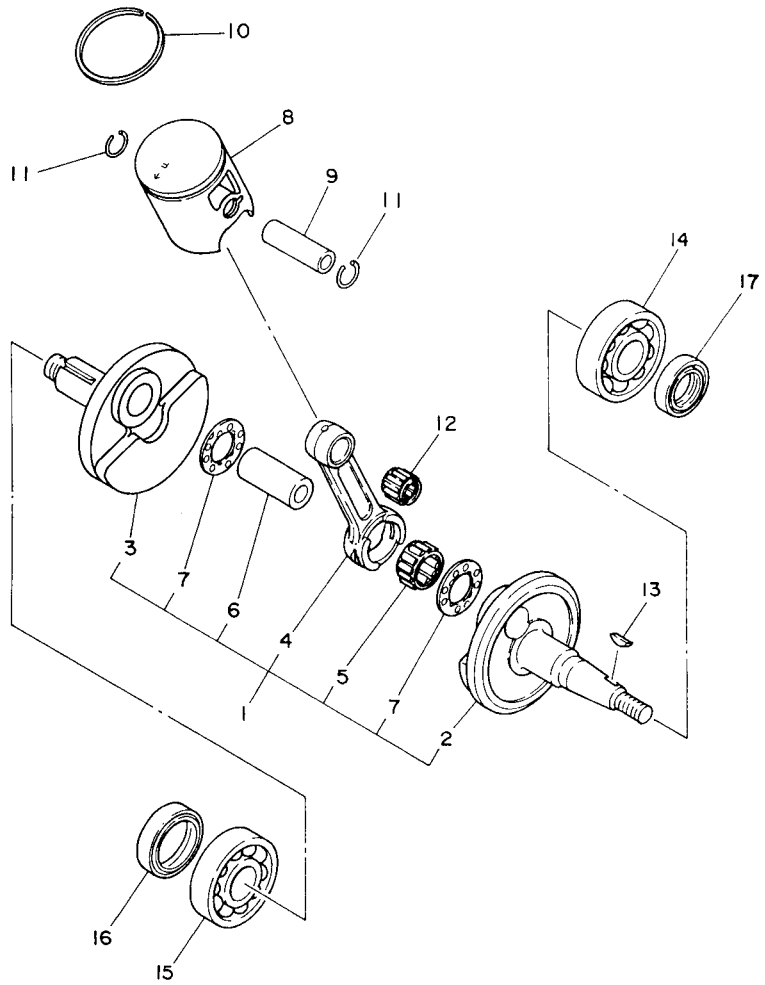

4ES1100-3020

FIG. 2 CRANKSHAFT & PISTON

REF. NO.	PART NO.	DESCRIPTION	SPAN	SPAR	SSHN	SSHR	REMARKS
1	5PA-11400-00	CRANKSHAFT ASSY	1	1	1	1	
2	5PA-11412-00	.CRANK 1	1	1	1	1	
3	5PA-11422-00	.CRANK 2	1	1	1	1	
4	4ES-11651-10	.ROD, CONNECTING	1	1	1	1	
5	93310-420B1	.BEARING	1	1	1	1	
6	2RA-11681-00	.PIN, CRANK 1	1	1	1	1	
7	90209-20159	.WASHER	2	2	2	2	
8	5PA-11631-00-A0	PISTON (STD)	1	1	1	1	UR RED
	5PA-11631-00-B0	PISTON (STD)	1	1	1	1	UR ORANGE
	5PA-11631-00-C0	PISTON (STD)	1	1	1	1	UR GREEN
	5PA-11631-00-D0	PISTON (STD)	1	1	1	1	UR PURPLE
9	4ES-11633-00	PIN, PISTON	1	1	1	1	
10	5PA-11611-00	RING, PISTON	1	1	1	1	
11	93450-16115	CIRCLIP	2	2	2	2	
12	93310-21417	BEARING	1	1	1	1	
13	90280-03017	KEY, WOODRUFF	1	1	1	1	
14	93306-20438	BEARING	1	1	1	1	
15	93306-30421	BEARING	1	1	1	1	
16	93102-28009	OIL SEAL	1	1	1	1	
17	93102-20447	OIL SEAL	1	1	1	1	

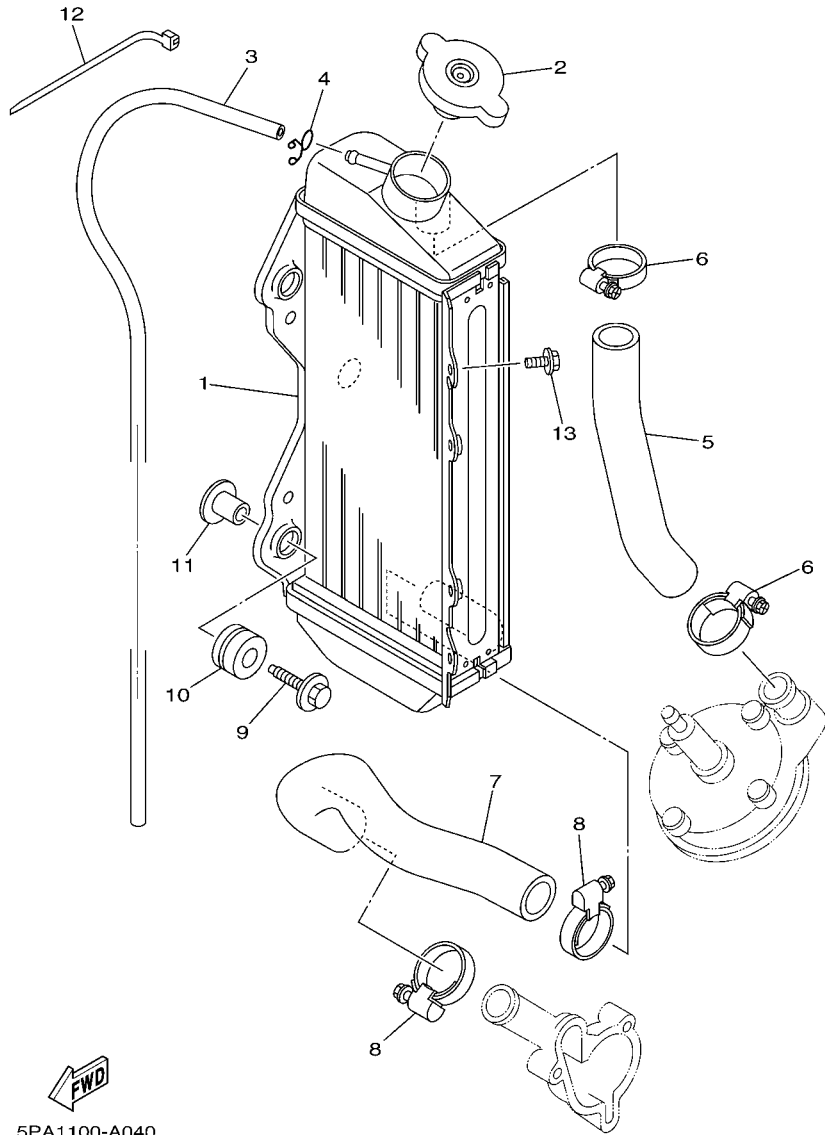

FIG. 4 RADIATOR & HOSE

REF. NO.	PART NO.	DESCRIPTION	SPAN	SPAR	SSHN	SSHR	REMARKS
1	5PA-12461-00	RADIATOR ASSY	1	1	1	1	
2	22W-12462-00	CAP, RADIATOR	1	1	1	1	
3	22W-12463-00	PIPE, BREATHER	1	1	1	1	
4	90467-08002	CLIP	1	1	1	1	
5	4ES-12481-10	PIPE 1	1	1	1	1	
6	90450-25037	HOSE CLAMP ASSY	2	2	2	2	
7	5PA-12482-00	PIPE 2	1	1	1	1	
8	90450-28014	HOSE CLAMP ASSY	2	2	2	2	
9	90119-06181	BOLT, WITH WASHER	3	3	3	3	
10	90480-15528	GROMMET	3	3	3	3	
11	90387-0614M	COLLAR	3	3	3	3	
12	90464-13077	CLAMP	2	2	2	2	
13	95822-06010	BOLT, FLANGE	1	1	1	1	

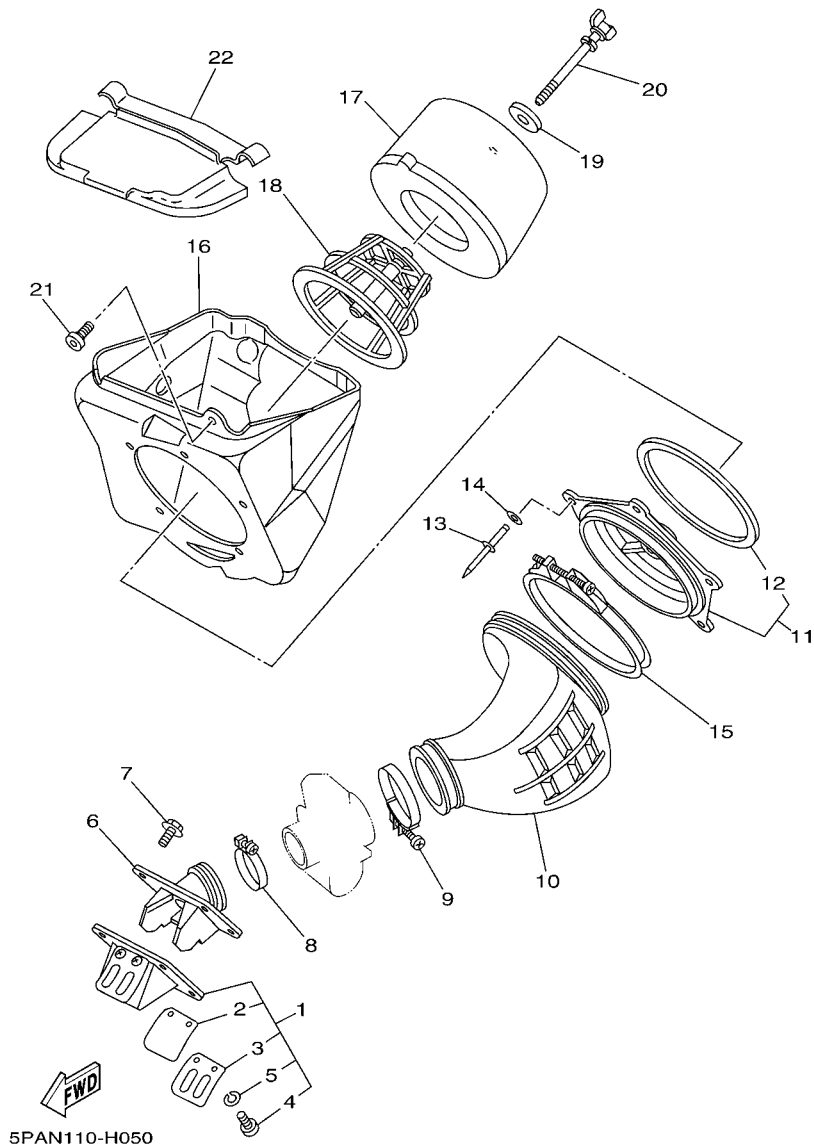
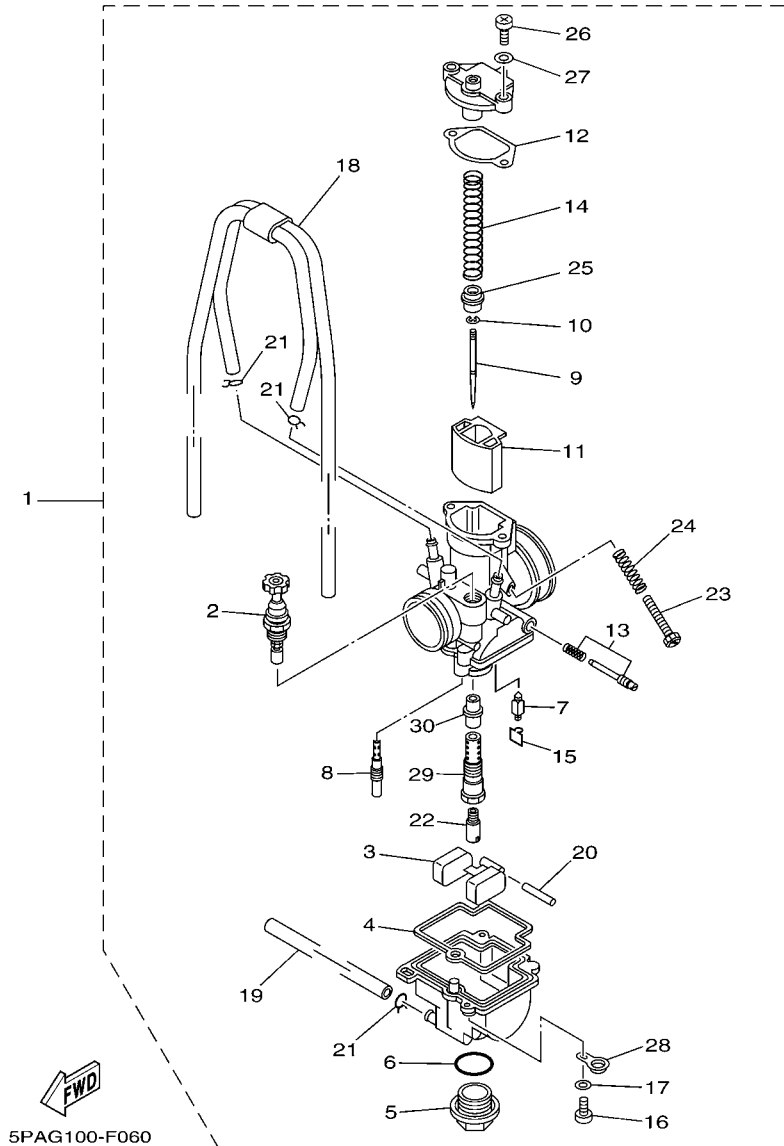

FIG. 5 INTAKE

REF. NO.	PART NO.	DESCRIPTION	SPAN	SPAR	SSHN	SSHR	REMARKS
1	4ES-13610-00	REED VALVE ASSY	1	1	1	1	
2	4ES-13613-00	.REED, VALVE	2	2	2	2	
3	4ES-13616-00	.STOPPER, REED VALVE	2	2	2	2	
4	98502-03006	.SCREW, PAN HEAD	4	4	4	4	
5	92902-03100	.WASHER	4	4	4	4	
6	5PA-13565-00	JOINT, CARBURETOR	1	1	1	1	
7	95022-06020	BOLT, FLANGE	4	4	4	4	
8	90450-41001	HOSE CLAMP ASSY	1	1	1	1	
9	90460-56071	CLAMP, HOSE	1	1	1	1	
10	5PA-14453-00	JOINT, AIR CLEANER 1	1	1	1	1	
11	5PA-14459-00	HOLDER, GUIDE	1	1	1	1	
12	4ES-14462-00	.SEAL	1	1	1	1	
13	90267-48138	RIVET, BLIND	5	5	5	5	
14	90201-043H7	WASHER, PLATE	5	5	5	5	
15	90450-99064	HOSE CLAMP ASSY	1	1	1	1	
16	5PA-14411-10	CASE, AIR CLEANER 1	1	1	1	1	
17	5PA-14451-00	ELEMENT, AIR CLEANER	1	1	1	1	
18	5PA-14458-00	GUIDE	1	1	1	1	
19	90209-06096	WASHER	1	1	1	1	
20	90122-06010	BOLT, WING	1	1	1	1	
21	90109-065F3	BOLT	1	1	1	1	
22	5PA-14417-00	COVER 1	1	1	1	1	AP



5PAG100-F060

FIG. 6 CARBURETOR

REF. NO.	PART NO.	DESCRIPTION	SPAN	SPAR	SSHN	SSHR	REMARKS
1	5PA-14101-00	CARBURETOR ASSY 1	1	1	1	1	
2	4JT-14171-00	.PLUNGER, STARTER	1	1	1	1	
3	5PA-14985-00	.FLOAT	1	1	1	1	
4	5PA-14984-00	.GASKET, FLOAT CHAMBER	1	1	1	1	
5	4MX-14115-00	.PLUG, SCREW	1	1	1	1	
6	4MX-14561-00	.O-RING	1	1	1	1	
7	5PA-14392-00	.VALVE, NEEDLE	1	1	1	1	
8	4MX-14948-05	.JET, SLOW (#45)	1	1	1	1	STD
	4MX-14948-04	.JET, SLOW (#42)	1	1	1	1	AP
	4MX-14948-06	.JET, SLOW (#48)	1	1	1	1	AP
9	5PA-14916-KF	.NEEDLE (NBKF)	1	1	1	1	STD
	5PA-14916-LE	.NEEDLE (NBLE)	1	1	1	1	AP
	5PA-14916-LF	.NEEDLE (NBLF)	1	1	1	1	AP
	5PA-14916-LG	.NEEDLE (NBLG)	1	1	1	1	AP
	5PA-14916-KE	.NEEDLE (NBKE)	1	1	1	1	AP
	5PA-14916-KG	.NEEDLE (NBKG)	1	1	1	1	AP
10	4MX-14919-00	.CLIP	1	1	1	1	
11	5PA-14340-00	.VALVE ASSY	1	1	1	1	
12	5PA-14126-00	.GASKET	1	1	1	1	
13	5PA-14105-00	.PILOT SCREW SET	1	1	1	1	
14	5PA-14131-00	.SPRING, THROTTLE VALVE	1	1	1	1	
15	5PA-14159-00	.CLIP	1	1	1	1	
16	98504-04014	.SCREW, PAN HEAD	2	2	2	2	
17	92903-04600	.WASHER	2	2	2	2	
18	5PA-1410E-00	.HOSE	1	1	1	1	
19	4XL-14197-10	.PIPE	1	1	1	1	
20	676-14548-00	.PIN, FLOAT ARM	1	1	1	1	

FIG. 7 EXHAUST

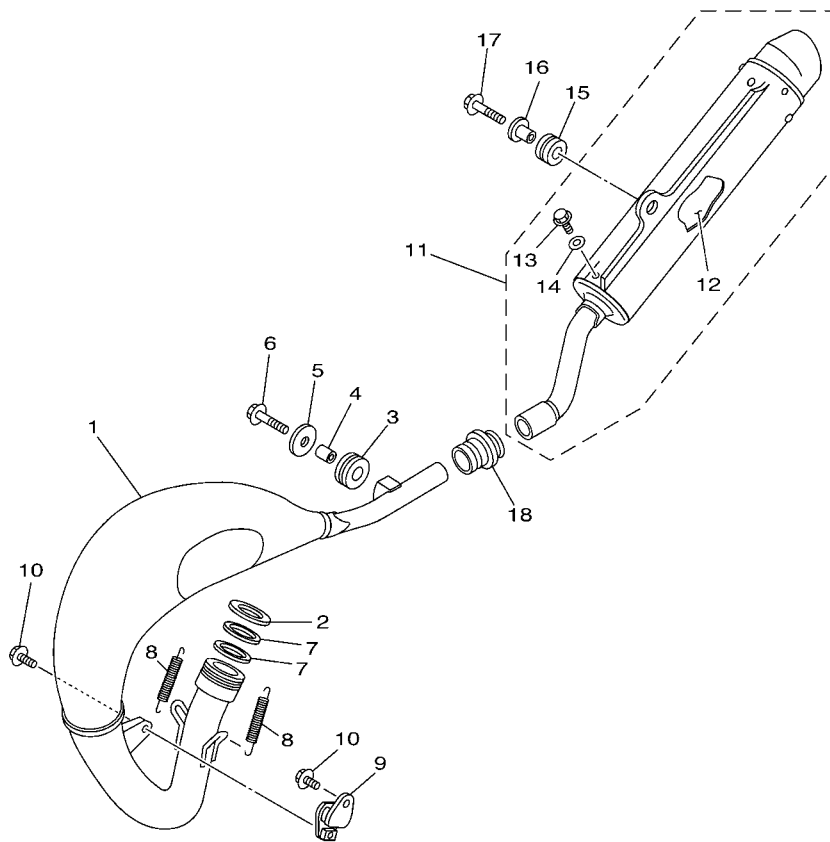

REF. NO.	PART NO.	DESCRIPTION	SPAN	SPAR	SSHN	SSHR	REMARKS
1	5PA-14610-00	EXHAUST PIPE ASSY 1	1	1	1	1	
2	90201-33299	WASHER, PLATE	1	1	1	1	
3	90480-18411	GROMMET	1	1	1	1	
4	90387-105L0	COLLAR	1	1	1	1	
5	90201-06086	WASHER, PLATE	1	1	1	1	
6	95022-06025	BOLT, FLANGE	1	1	1	1	
7	5PA-14642-00	SEAL, EXHAUST	2	2	2	2	
8	90507-20052	SPRING, TENSION	2	2	2	2	
9	565-14771-00	STAY, MUFFLER 1	1	1	1	1	
10	90119-06217	BOLT, WITH WASHER	2	2	2	2	
11	4ES-14753-20	SILENCER, EXHAUST	1	1	1	1	UR FOR CAN,ZAF
12	4ES-1469A-00	.FIBER	1	1	1	1	UR FOR CAN,ZAF
13	92012-06010	.BOLT, BUTTON HEAD	2	2	2	2	
14	90201-06089	.WASHER, PLATE	2	2	2	2	
15	90480-16561	GROMMET	1	1	1	1	
16	90387-06168	COLLAR	1	1	1	1	
17	95022-06025	BOLT, FLANGE	1	1	1	1	
18	17W-14615-00	JOINT, EXHAUST 1	1	1	1	1	



5PA4100-B070

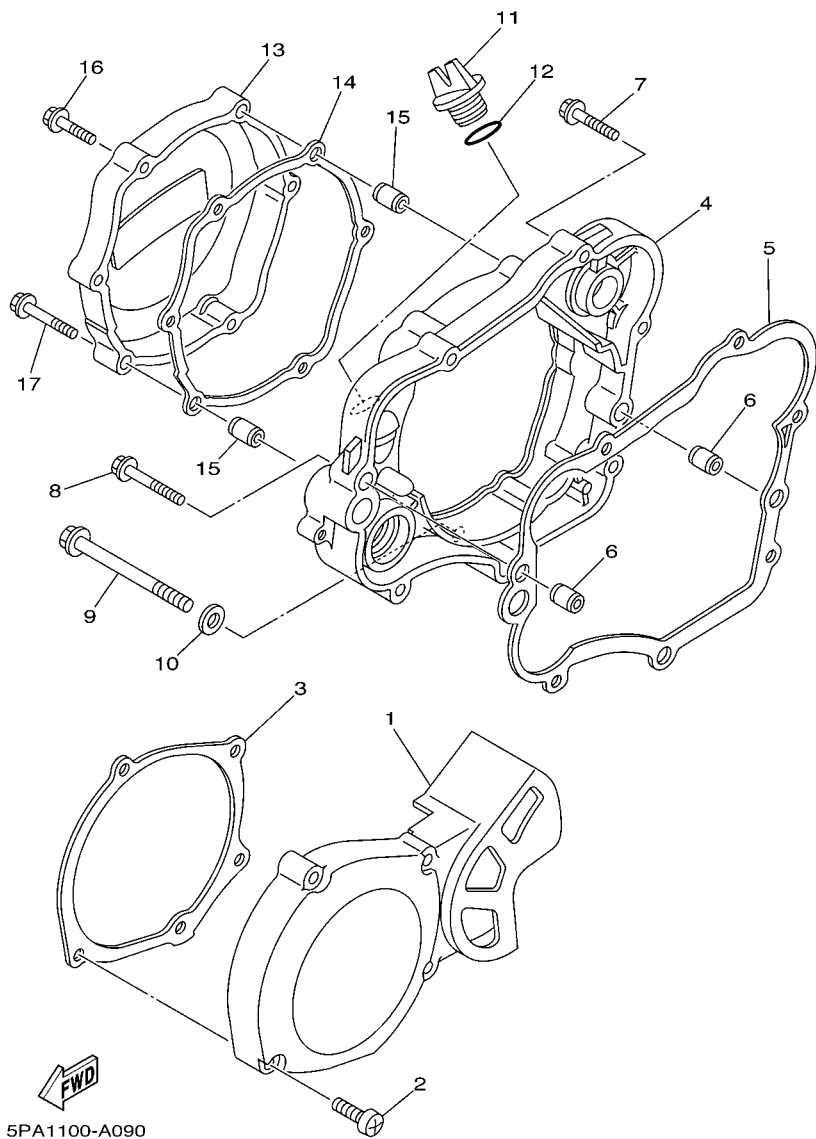
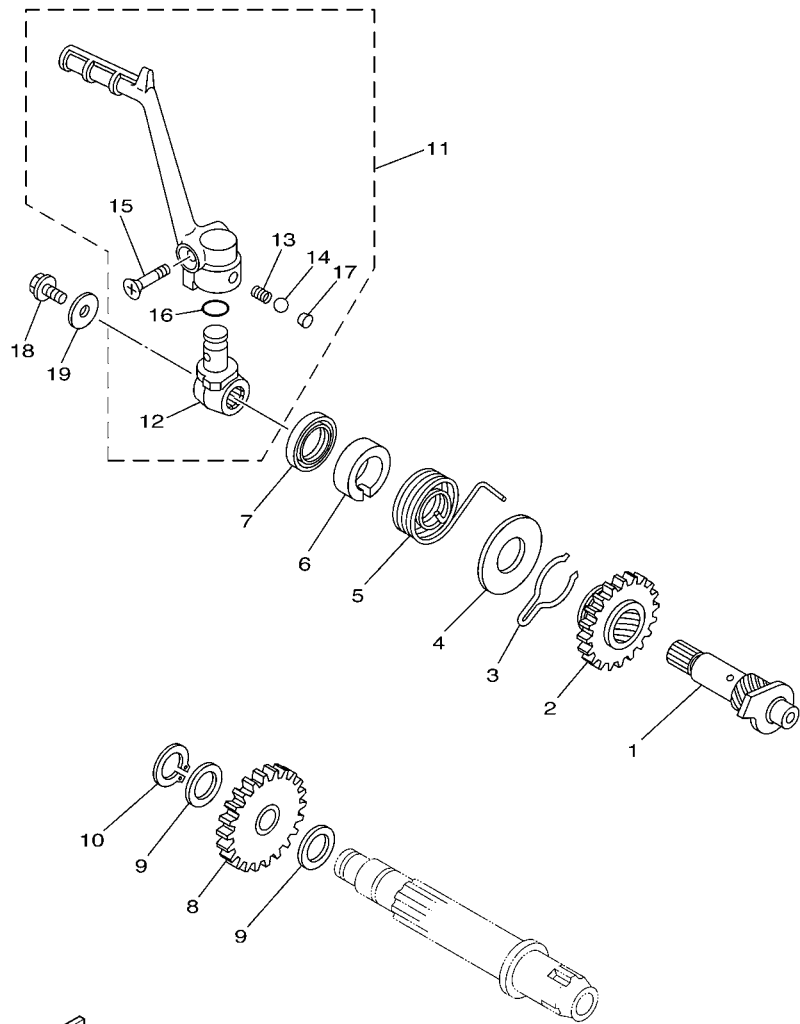

FIG. 9 CRANKCASE COVER 1

REF. NO.	PART NO.	DESCRIPTION	SPAN	SPAR	SSHN	SSHR	REMARKS
1	4ES-15411-00	COVER, CRANKCASE 1	1	1	1	1	
2	98502-06030	SCREW, PAN HEAD	4	4	4	4	
3	5PA-15451-00	GASKET, CRANKCASE COVER 1	1	1	1	1	
4	5PA-15431-00	COVER, CRANKCASE 3	1	1	1	1	
5	4ES-15461-00	GASKET, CRANKCASE COVER 2	1	1	1	1	
6	99530-10014	PIN, DOWEL	2	2	2	2	
7	95022-06030	BOLT, FLANGE	4	4	4	4	
8	95022-06040	BOLT, FLANGE	1	1	1	1	
9	95022-08080	BOLT, FLANGE	1	1	1	1	
10	90430-08119	GASKET	1	1	1	1	
11	3Y1-15363-00	PLUG, OIL	1	1	1	1	
12	93210-19123	O-RING	1	1	1	1	
13	5PA-15415-10	COVER, GENERATOR	1	1	1	1	
14	5PA-15463-00	GASKET, COVER PINION 2	1	1	1	1	
15	99530-08016	PIN, DOWEL	2	2	2	2	
16	95022-06025	BOLT, FLANGE	4	4	4	4	
17	95022-06035	BOLT, FLANGE	2	2	2	2	



5PA1100-A100

FIG. 10 STARTER

REF. NO.	PART NO.	DESCRIPTION	SPAN	SPAR	SSHN	SSHR	REMARKS
1	5PA-15660-00	KICK AXLE ASSY	1	1	1	1	
2	5PA-15641-00	GEAR, KICK	1	1	1	1	
3	90468-23194	CLIP	1	1	1	1	
4	90201-176L4	WASHER, PLATE	1	1	1	1	
5	90508-26750	SPRING, TORSION	1	1	1	1	
6	4ES-15664-00	GUIDE, SPRING	1	1	1	1	
7	93102-17263	OIL SEAL	1	1	1	1	
8	5PA-15651-00	GEAR, KICK IDLE	1	1	1	1	
9	90201-124F8	WASHER, PLATE	2	2	2	2	
10	99009-12400	CIRCLIP	1	1	1	1	
11	5PA-15620-01	KICK CRANK ASSY	1	1	1	1	
12	5PA-15621-00	.BOSS, KICK CRANK	1	1	1	1	
13	90501-12081	.SPRING, COMPRESSION	1	1	1	1	
14	93507-32009	.BALL	1	1	1	1	
15	90151-06045	.SCREW, COUNTERSUNK	1	1	1	1	
16	93210-12152	.O-RING	1	1	1	1	
17	90336-06031	.PLUG, TAPER	1	1	1	1	
18	95022-06012	BOLT, FLANGE	1	1	1	1	
19	90201-06060	WASHER, PLATE	1	1	1	1	

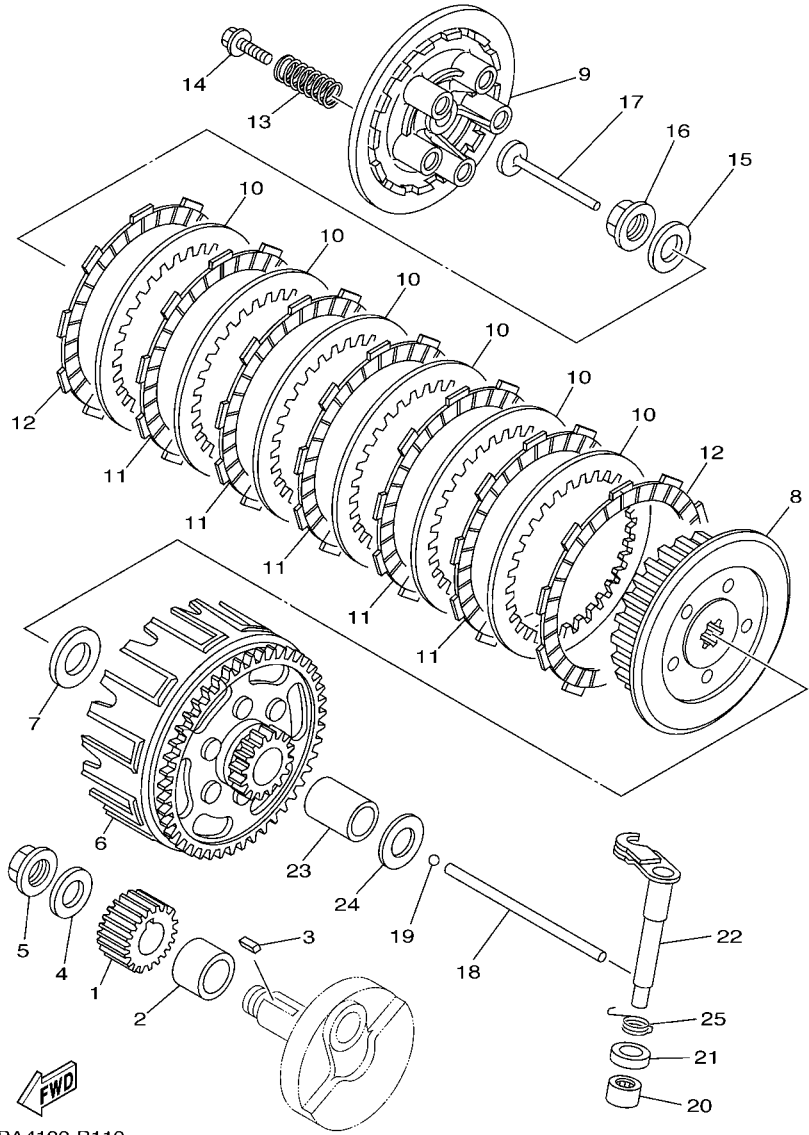

5PA4100-B110

FIG. 11 CLUTCH

REF. NO.	PART NO.	DESCRIPTION	SPAN	SPAR	SSHN	SSHR	REMARKS
1	5PA-16111-00	GEAR, PRIMARY DRIVE	1	1	1	1	
2	90387-20488	COLLAR	1	1	1	1	
3	90282-05001	KEY, STRAIGHT (5MMX16MM)	1	1	1	1	
4	90208-12015	WASHER, CONICAL SPRING	1	1	1	1	
5	90179-12007	NUT	1	1	1	1	
6	5PA-16150-10	PRIMARY DRIVEN GEAR COMP.	1	1	1	1	
7	90201-17558	WASHER, PLATE	1	1	1	1	
8	5PA-16371-10	BOSS, CLUTCH	1	1	1	1	
9	2TK-16351-00	PLATE, PRESSURE 1	1	1	1	1	
10	131-16324-00	PLATE, CLUTCH 1	6	6	6	6	
11	4ES-16321-00	PLATE, FRICTION	5	5	5	5	
12	21V-16321-00	PLATE, FRICTION	2	2	2	2	
13	90501-204A0	SPRING, COMPRESSION	5	5	5	5	
14	90119-05001	BOLT, WITH WASHER	5	5	5	5	
15	90208-12015	WASHER, CONICAL SPRING	1	1	1	1	
16	90179-12007	NUT	1	1	1	1	
17	4ES-16356-00	ROD, PUSH 1	1	1	1	1	
18	5PA-16357-00	ROD, PUSH 2	1	1	1	1	
19	93503-16003	BALL	1	1	1	1	
20	93315-11206	BEARING	1	1	1	1	
21	93102-12224	OIL SEAL	1	1	1	1	
22	4ES-16381-00	PUSH LEVER COMP.	1	1	1	1	
23	5PA-16181-00	SPACER 1	1	1	1	1	
24	90201-171G6	WASHER, PLATE	1	1	1	1	
25	90508-14016	SPRING, TORSION	1	1	1	1	

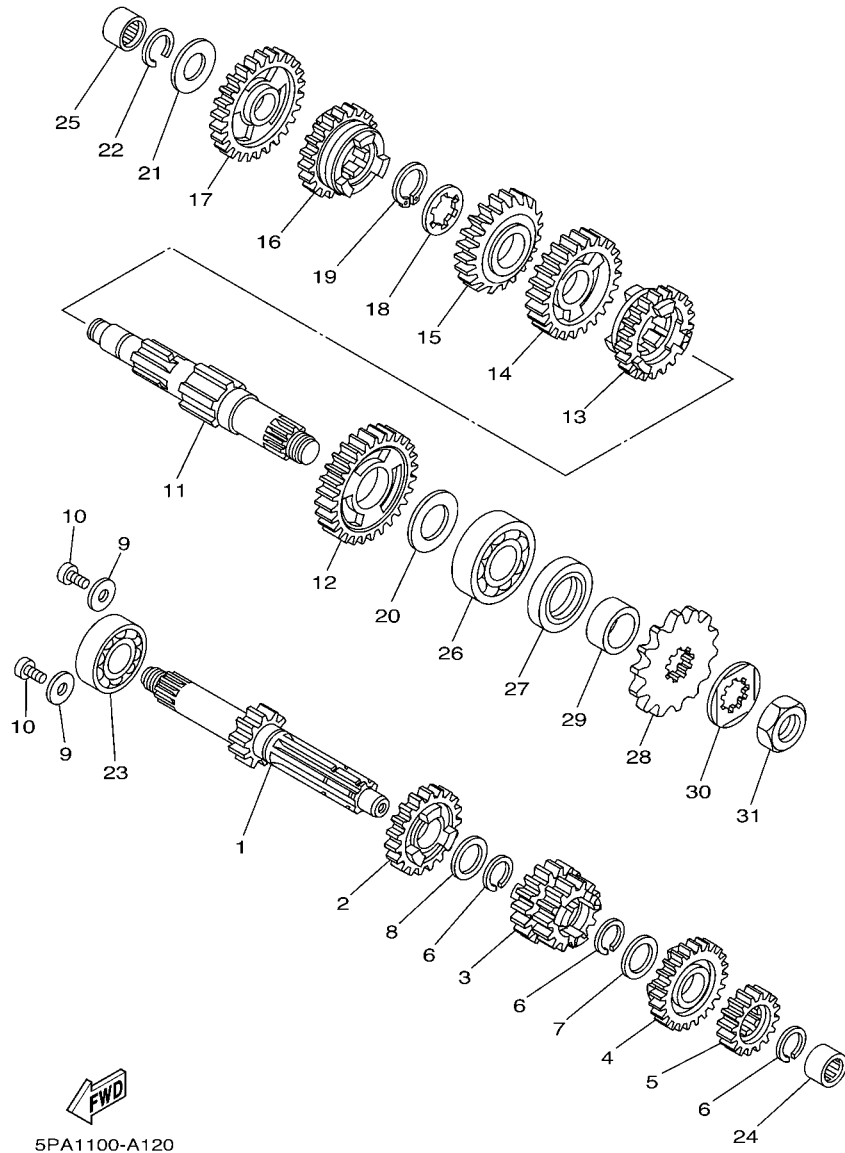

FIG. 12 TRANSMISSION

REF. NO.	PART NO.	DESCRIPTION	SPAN	SPAR	SSHN	SSHR	REMARKS
1	5PA-17411-00	AXLE, MAIN (11T)	1	1	1	1	
2	4ES-17151-10	GEAR, 5TH PINION (23T)	1	1	1	1	
3	4ES-17131-03	GEAR, 3RD PINION (17T/17T)	1	1	1	1	
4	4ES-17161-10	GEAR, 6TH PINION (25T)	1	1	1	1	
5	4ES-17121-01	GEAR, 2ND PINION (17T)	1	1	1	1	
6	93440-17064	CIRCLIP	3	3	3	3	
7	90209-14008	WASHER	1	1	1	1	
8	90201-17545	WASHER, PLATE	1	1	1	1	
9	90201-06060	WASHER, PLATE	2	2	2	2	
10	90157-06008	SCREW, PAN HEAD	2	2	2	2	
11	5PA-17421-00	AXLE, DRIVE	1	1	1	1	
12	5PA-17221-00	GEAR, 2ND WHEEL (32T)	1	1	1	1	
13	5PA-17261-00	GEAR, 6TH WHEEL (25T)	1	1	1	1	
14	4ES-17231-10	GEAR, 3RD WHEEL (26T)	1	1	1	1	
15	5PA-17241-00	GEAR, 4TH WHEEL (22T)	1	1	1	1	
16	4ES-17251-00	GEAR, 5TH WHEEL (26T)	1	1	1	1	
17	4ES-17211-01	GEAR, 1ST WHEEL (27T)	1	1	1	1	
18	90209-16209	WASHER	1	1	1	1	
19	93410-20038	CIRCLIP	1	1	1	1	
20	90201-20611	WASHER, PLATE	1	1	1	1	
21	164-17427-00-06	SHIM 1 (T=0.6)	1	1	1	1	UR
	164-17427-00-08	SHIM 1 (T=0.8)	1	1	1	1	UR
	164-17427-00-10	SHIM 1 (T=1.0)	1	1	1	1	UR
22	93440-15012	CIRCLIP	1	1	1	1	
23	93306-20333	BEARING	1	1	1	1	
24	93317-11245	BEARING	1	1	1	1	
25	93315-31502	BEARING	1	1	1	1	

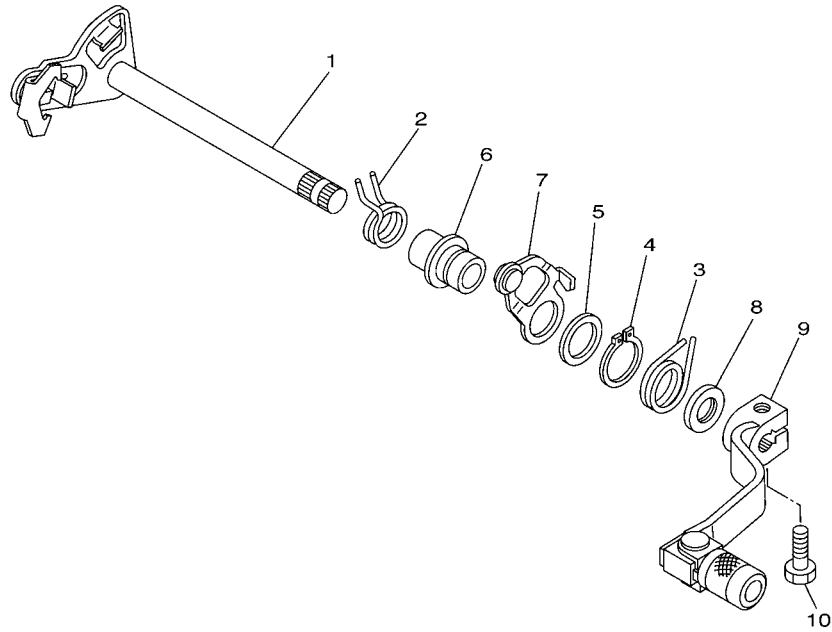

FIG. 14 SHIFT SHAFT

REF. NO.	PART NO.	DESCRIPTION	SPAN	SPAR	SSHN	SSHR	REMARKS
1	5PA-18101-00	SHIFT SHAFT ASSY	1	1	1	1	
2	90508-32016	SPRING, TORSION	1	1	1	1	
3	90508-24007	SPRING, TORSION	1	1	1	1	
4	99009-17400	CIRCLIP	1	1	1	1	
5	90201-177G4	WASHER, PLATE	1	1	1	1	
6	5PA-1811E-00	COLLAR,SHIFT PEDAL	1	1	1	1	
7	5PA-18140-00	STOPPER LEVER ASSY	1	1	1	1	
8	93101-12173	OIL SEAL	1	1	1	1	
9	2HF-18110-02	SHIFT PEDAL ASSY	1	1	1	1	
10	97022-06020	BOLT	1	1	1	1	



5PA1100-A140

FIG. 15 FRAME

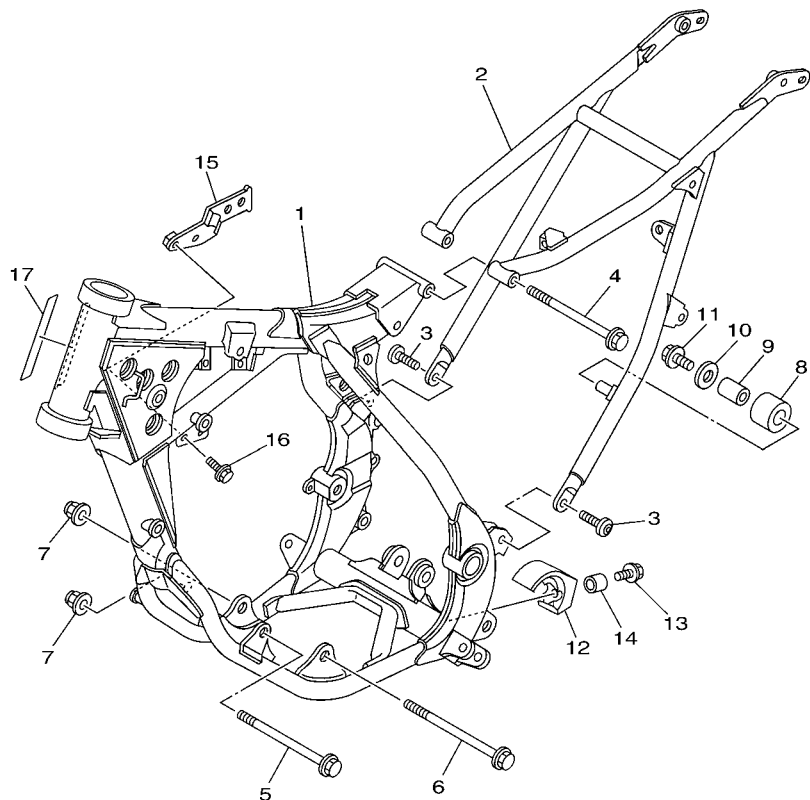

REF. NO.	PART NO.	DESCRIPTION	SPAN	SPAR	SSHN	SSHR	REMARKS
1	5PA-21101-12-33	FRONT FRAME COMP.	1	1	1	1	YB FOR DPBSE
2	5PA-21190-00-33	REAR FRAME COMP.	1	1	1	1	YB FOR DPBSE
3	90111-08029	BOLT,HEX. SOCKET BUTTON	2	2	2	2	
4	95812-08125	BOLT, FLANGE	1	1	1	1	
5	90105-10220	BOLT, FLANGE	1	1	1	1	
6	90105-10219	BOLT, FLANGE	1	1	1	1	
7	95602-10200	NUT, U FLANGE	2	2	2	2	
8	30X-22178-00	TENSIONER	1	1	1	1	
9	4V4-22184-00	BUSH	1	1	1	1	
10	90201-08078	WASHER, PLATE	1	1	1	1	
11	95022-08012	BOLT, FLANGE	1	1	1	1	
12	4ES-22178-00	TENSIONER	1	1	1	1	
13	90119-06159	BOLT, WITH WASHER	1	1	1	1	
14	90387-067K6	COLLAR	1	1	1	1	
15	5PA-21274-10	BRACKET, C.D.I. UNIT	1	1	1	1	
16	95022-06012	BOLT, FLANGE	2	2	2	2	
17	3HA-24141-00	PROTECTOR, FUEL TANK	1	1	1	1	

5PAK100-G150

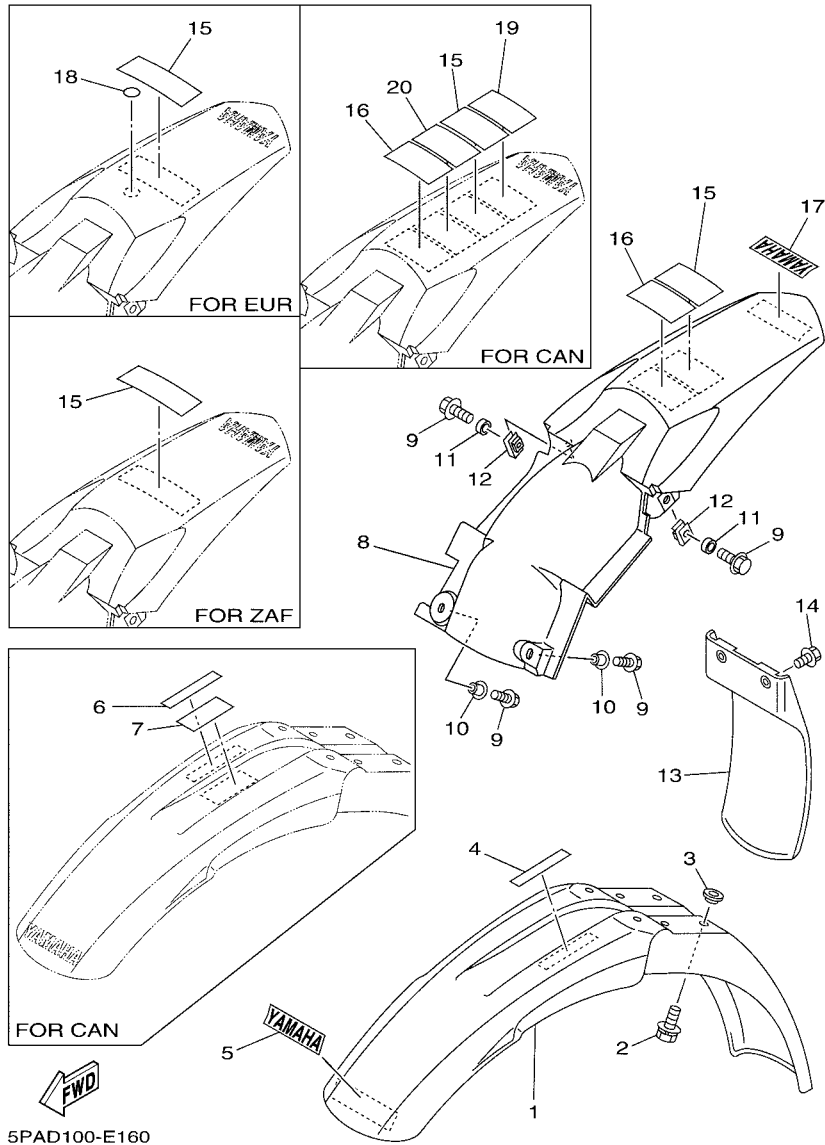
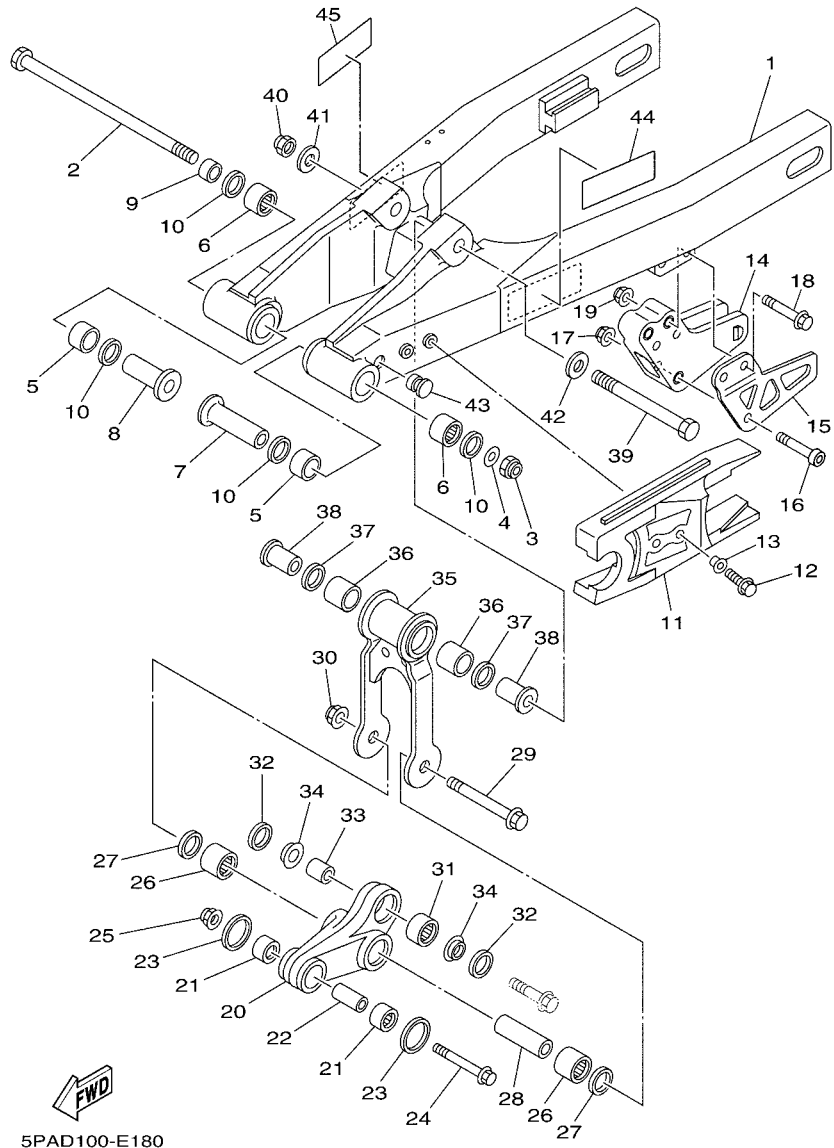

FIG. 16 FENDER

REF. NO.	PART NO.	DESCRIPTION	SPAN	SPAF	SSHN	SSHR	REMARKS
1	4ES-21511-20	FENDER, FRONT	1	1	1	1	
2	90119-06201	BOLT, WITH WASHER	4	4	4	4	
3	90209-06015	WASHER	4	4	4	4	
4	3XJ-2415E-A1	LABEL, CAUTION	1				FOR EUR,ZAF
5	4ES-2153E-01	EMBLEM, YAMAHA	1	1	1	1	
8	5PA-21611-00	FENDER, REAR	1	1	1	1	
9	90119-06133	BOLT, WITH WASHER	4	4	4	4	
10	90387-064X4	COLLAR	2	2	2	2	
11	90387-0701A	COLLAR	2	2	2	2	
12	90183-060A7	NUT, SPRING	2	2	2	2	
13	4ES-21642-00	GUARD, FLAP	1	1	1	1	
14	90119-06239	BOLT, WITH WASHER	2	2	2	2	
15	5PA-2118K-00	LABEL, CAUTION	1				UR FOR CAN
	5PA-21568-01	LABEL, WARNING	1	1			UR FOR EUR,ZAF
17	4ES-2153E-01	EMBLEM, YAMAHA	1	1	1	1	



5PAD100-E180

FIG. 18 REAR ARM

REF. NO.	PART NO.	DESCRIPTION	SPAN	SPAR	SSH	SSHR	REMARKS
1	5PA-22110-00	REAR ARM COMP.	1	1			
	5SH-22110-10	REAR ARM COMP.			1	1	
2	22W-25181-01	AXLE, WHEEL	1	1	1	1	
3	95612-12100	NUT, U	1	1	1	1	
4	90201-12032	WASHER, PLATE	1	1	1	1	
5	90385-17042	BUSH	2	2	2	2	
6	93317-21746	BEARING	2	2	2	2	
7	90387-127J8	COLLAR	1	1	1	1	
8	90387-127J7	COLLAR	1	1	1	1	
9	90387-1200U	COLLAR	1	1	1	1	
10	93109-17071	OIL SEAL	4	4	4	4	
11	5PA-22151-00	SEAL, GUARD	1	1	1	1	
12	95022-06014	BOLT, FLANGE	2	2	2	2	
13	90387-06180	COLLAR	2	2	2	2	
14	5PA-22199-00	SUPPORT, CHAIN	1	1	1	1	
15	5PA-22128-00	COVER, THRUST 1	1	1	1	1	
16	92012-06040	BOLT, BUTTON HEAD	1	1	1	1	
17	95602-06200	NUT, SELF-LOCKING	1	1	1	1	
18	95022-08050	BOLT, FLANGE	2	2	2	2	
19	95602-08200	NUT, SELF-LOCKING	2	2	2	2	
20	5PA-2217A-00	ARM, RELAY	1	1	1	1	
21	93315-21455	BEARING	2	2	2	2	
22	90380-10218	BUSH, SOLID	1	1	1	1	
23	4ES-22129-00	COVER, THRUST 2	2	2	2	2	
24	90105-10582	BOLT, FLANGE	1	1	1	1	
25	95602-10200	NUT, U FLANGE	1	1	1	1	
26	93317-31771	BEARING	2	2	2	2	

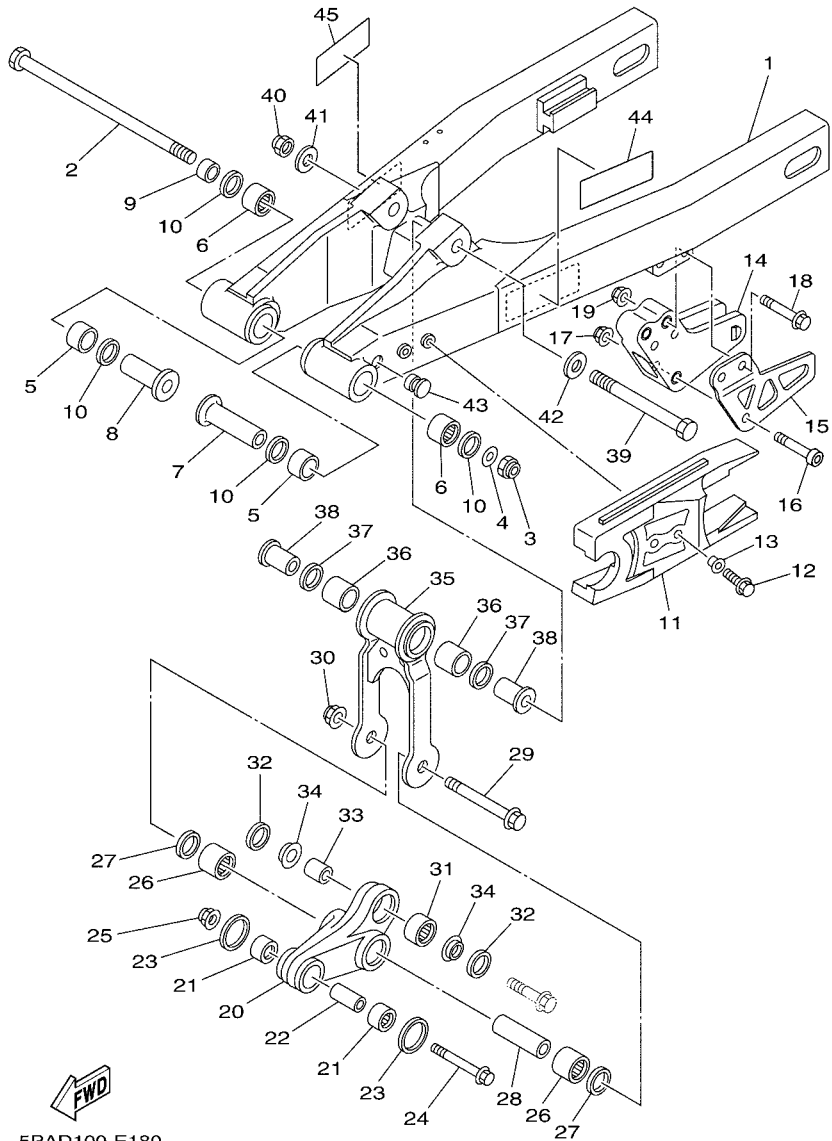
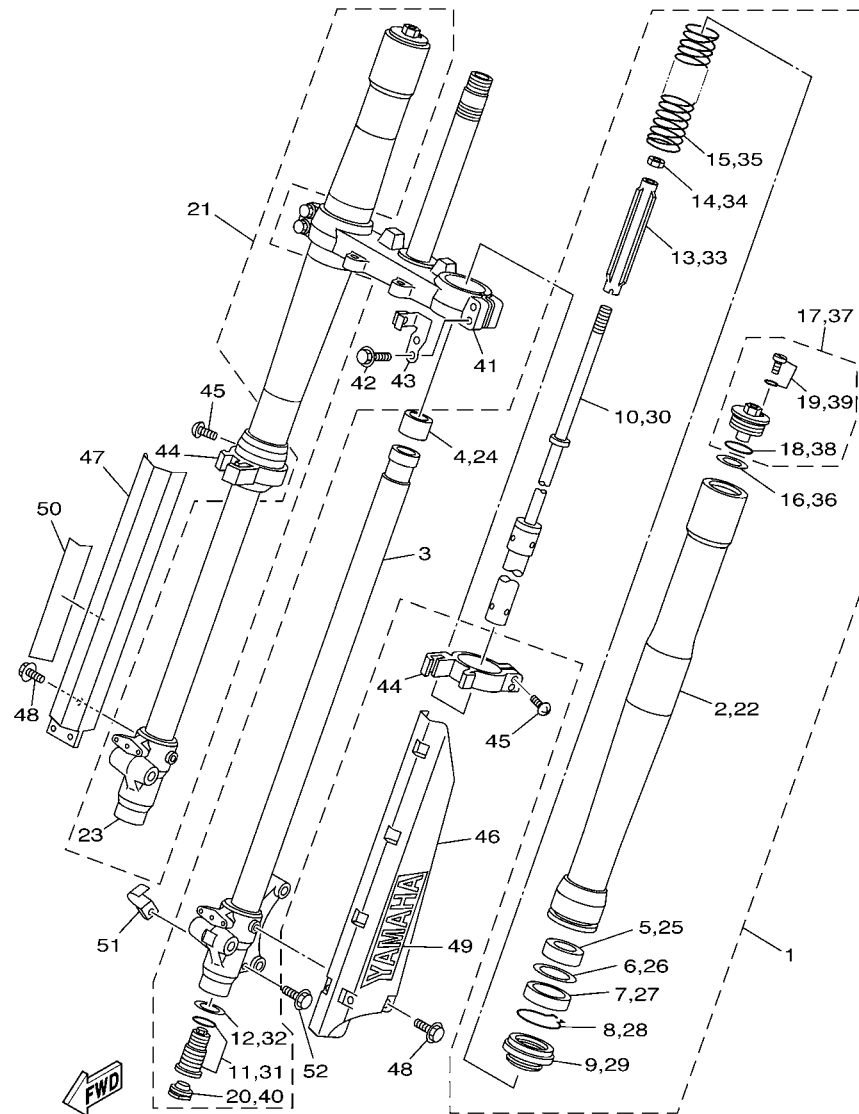

FIG. 18 REAR ARM

REF. NO.	PART NO.	DESCRIPTION	SPAN	SPAR	SSH-N	SSH-R	REMARKS
27	93101-17062	OIL SEAL	2	2	2	2	
28	90380-12219	BUSH, SOLID	1	1	1	1	
29	90109-12015	BOLT	1	1	1	1	
30	95602-12200	NUT, SELF-LOCKING	1	1	1	1	
31	5PA-22176-00	BEARING	1	1	1	1	
32	5PA-22475-00	SEAL, DUST	2	2	2	2	
33	5PA-22184-00	BUSH	1	1	1	1	
34	5PA-22253-00	COLLAR, DISTANCE	2	2	2	2	
35	4ES-2217F-00	ROD, CONNECTING 1	1	1	1	1	
36	93317-31771	BEARING	2	2	2	2	
37	93101-17062	OIL SEAL	2	2	2	2	
38	90381-12091	BUSH, SOLID	2	2	2	2	
39	90101-12755	BOLT	1	1	1	1	
40	90185-12011	NUT, SELF-LOCKING	1	1	1	1	
41	90201-12047	WASHER, PLATE	1	1	1	1	
42	90201-12049	WASHER, PLATE	1	1	1	1	
43	90338-10150	PLUG	2	2	2	2	



5PA7100-C210

FIG. 21 FRONT FORK

REF. NO.	PART NO.	DESCRIPTION	SPAN	SPAR	SSH	SSHR	REMARKS
1	5PA-23102-10	FRONT FORK ASSY (L.H)	1	1			
	5SH-23102-10	FRONT FORK ASSY (L.H)			1	1	
2	5PA-23136-10	.TUBE, OUTER (RIGHT)	1	1	1	1	
3	5PA-23120-00	.INNER TUBE COMP.2	1	1	1	1	
4	5PA-23171-00	.PISTON, FRONT FORK	1	1	1	1	
5	5PA-23125-00	.METAL, SLIDE 1	1	1	1	1	
6	5K5-23149-00	.WASHER, SPRING UPPER	1	1	1	1	
7	4ES-23145-00	.OIL SEAL	1	1	1	1	
8	4A1-23156-00	.RING, SNAP	1	1	1	1	
9	4ES-23144-00	.SEAL, DUST	1	1	1	1	
10	5PA-23170-00	.CYLINDER COMP., FRONT FORK	1	1	1	1	
11	5PA-2316A-00	.VALVE COMP.	1	1			
	5SH-2316A-00	.VALVE COMP.			1	1	
12	2HH-23158-L0	.GASKET	1	1	1	1	
13	4ES-23142-00	.SEAT, SPRING UPPER	1	1	1	1	
14	3XJ-23357-L0	.NUT	1	1	1	1	
15	4ES-23141-40	.SPRING, FRONT FORK(K=2.8N/MM)	1	1			
	4LB-23141-10	.SPRING, FRONT FORK(K=2.9N/MM)			1	1	
16	5PA-23149-00	.WASHER, SPRING UPPER	1	1	1	1	
17	4ES-23111-10	.BOLT, CAP	1	1	1	1	
18	4V4-23188-L0	.O-RING	1	1	1	1	
19	3JD-23394-00	.BOLT, SPECIAL	1	1	1	1	
20	3JD-2312G-L0	.PLUG	1	1	1	1	
21	5PA-23103-10	FRONT FORK ASSY (R.H)	1	1			
	5SH-23103-10	FRONT FORK ASSY (R.H)			1	1	
22	5PA-23136-10	.TUBE, OUTER (RIGHT)	1	1	1	1	
23	5PA-23110-00	.INNER TUBE COMP.1	1	1	1	1	

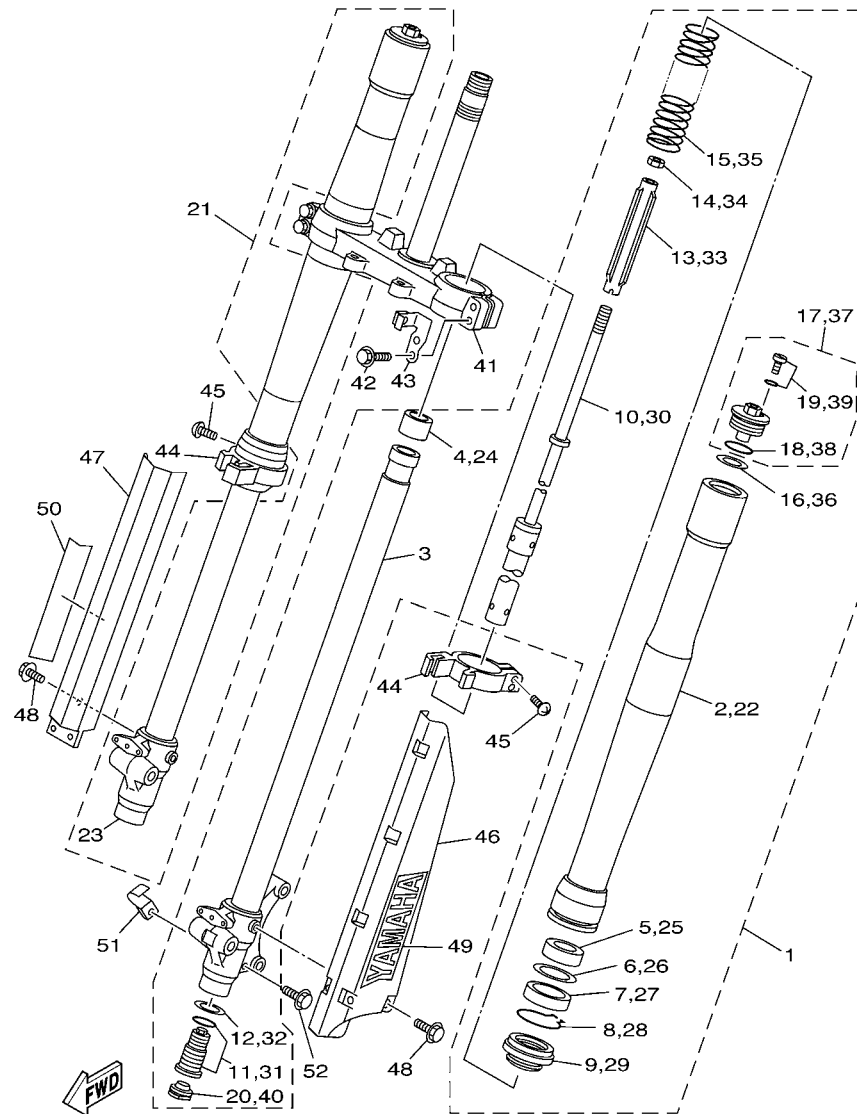

5PA7100-C210

FIG. 21 FRONT FORK

REF. NO.	PART NO.	DESCRIPTION	SPAN	SPAR	SSHN	SSHR	REMARKS
24	5PA-23171-00	.PISTON, FRONT FORK	1	1	1	1	
25	5PA-23125-00	.METAL, SLIDE 1	1	1	1	1	
26	5K5-23149-00	.WASHER, SPRING UPPER	1	1	1	1	
27	4ES-23145-00	.OIL SEAL	1	1	1	1	
28	4A1-23156-00	.RING, SNAP	1	1	1	1	
29	4ES-23144-00	.SEAL, DUST	1	1	1	1	
30	5PA-23170-00	.CYLINDER COMP., FRONT FORK	1	1	1	1	
31	5PA-2316A-00	.VALVE COMP.	1	1			
	5SH-2316A-00	.VALVE COMP.			1	1	
32	2HH-23158-L0	.GASKET	1	1	1	1	
33	4ES-23142-00	.SEAT, SPRING UPPER	1	1	1	1	
34	3XJ-23357-L0	.NUT	1	1	1	1	
35	4ES-23141-40	.SPRING, FRONT FORK(K=2.8N/MM)	1	1			
	4LB-23141-10	.SPRING, FRONT FORK(K=2.9N/MM)			1	1	
36	5PA-23149-00	.WASHER, SPRING UPPER	1	1	1	1	
37	4ES-23111-10	.BOLT, CAP	1	1	1	1	
38	4V4-23188-L0	.O-RING	1	1	1	1	
39	3JD-23394-00	.BOLT, SPECIAL	1	1	1	1	
40	3JD-2312G-L0	.PLUG	1	1	1	1	
41	5PA-23340-01	UNDER BRACKET COMP.	1	1	1	1	
42	5PA-23346-00	BOLT 1	4	4	4	4	
43	5PA-2331E-10	GUIDE, CABLE	1	1	1	1	
44	4ES-2314F-00	PROTECTOR GUIDE COMP., 1	2	2	2	2	
45	4V4-23194-L0	SCREW, BOOT BAND	4	4	4	4	
46	5PA-2314H-L0	PROTECTOR COMP., 1	1	1	1	1	
47	5PA-2314J-L0	PROTECTOR COMP., 2	1	1	1	1	
48	95024-06010	BOLT, FLANGE	6	6	6	6	

FIG. 22 FUEL TANK

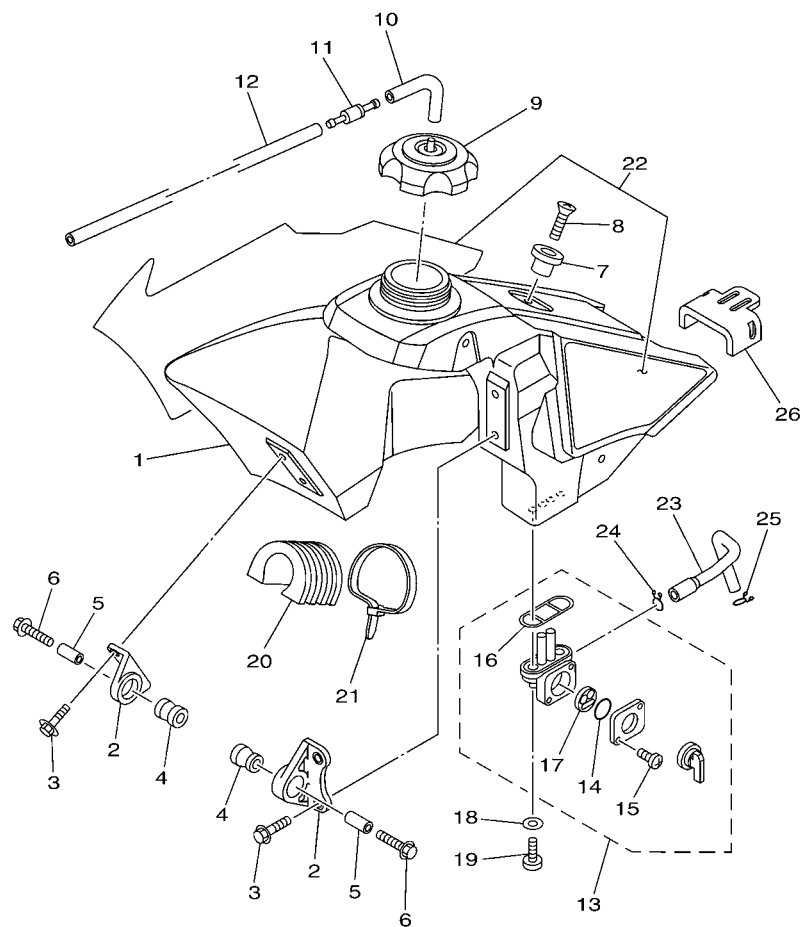

5PAK100-G220

REF. NO.	PART NO.	DESCRIPTION	SPAN	SPAR	SSHN	SSHR	REMARKS
1	5PA-24110-30	FUEL TANK COMP.	1	1	1	1	
2	5XE-24144-00	HOLDER, DAMPER	2	2	2	2	
3	95027-06016	BOLT, FLANGE	4	4	4	4	
4	90480-18549	GROMMET	2	2	2	2	
5	90387-06027	COLLAR	2	2	2	2	
6	90119-06190	BOLT, WITH WASHER	2	2	2	2	
7	4EW-2412F-00	BRACKET, SEAT	1	1	1	1	
8	98702-06025	SCREW, FLAT HEAD	1	1	1	1	
9	5NY-24610-00	CAP ASSY	1	1	1	1	
10	90445-09220	HOSE (L30)	1	1	1	1	
11	3XJ-24380-00	PIPE JOINT ASSY	1	1	1	1	
12	90445-09300	HOSE (L355)	1	1	1	1	
13	4DP-24500-01	FUEL COCK ASSY 1	1	1	1	1	
14	3AJ-24534-01	.SEAL, COCK	1	1	1	1	
15	98507-03008	.SCREW, PAN HEAD	2	2	2	2	
16	4X8-24512-00	.O-RING	1	1	1	1	
17	3AC-24523-00	.VALVE PACKING	1	1	1	1	
18	90202-05193	WASHER, PLATE	2	2	2	2	
19	90149-06108	SCREW	2	2	2	2	
20	5PA-24182-00	DAMPER, LOCATING 2	1	1	1	1	
21	90465-13275	CLAMP	1	1	1	1	
22	5PA-24240-70	GRAPHIC SET	1	1	1	1	
23	5PA-24311-00	PIPE, FUEL 1	1	1	1	1	
24	90467-10008	CLIP	1	1	1	1	
25	90467-09002	CLIP	1	1	1	1	
26	5PA-24181-00	DAMPER, LOCATING 1	1	1	1	1	

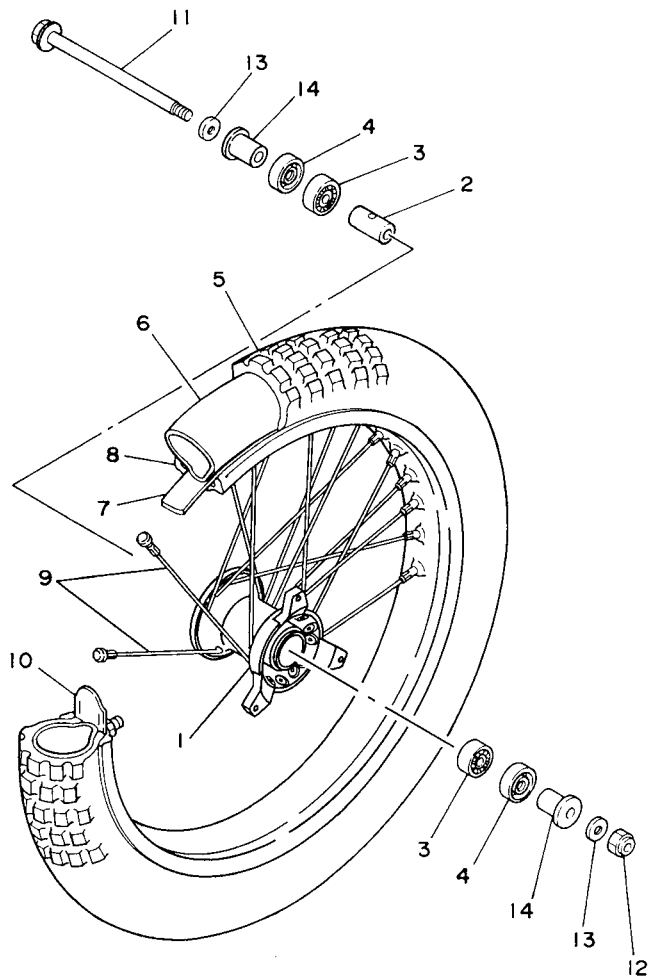

4ES1100-3240

FIG. 24 FRONT WHEEL

REF. NO.	PART NO.	DESCRIPTION	SPAN	SPAR	SSHN	SSHR	REMARKS
1	4ES-25111-00	HUB, FRONT	1	1	1	1	
2	90387-124H0	COLLAR	1	1	1	1	
3	93306-20120	BEARING	2	2	2	2	
4	93106-20031	OIL SEAL	2	2	2	2	
5	L.M.	TIRE (70/100-17 40M D756F)	1				
	L.M.	TIRE (70/100-19 42M D756F)			1		
6	L.M.	TUBE (70/100-17M/C TR4)	1				
	L.M.	TUBE (70/100-19M/C TR4)			1		
7	94307-17166	BAND, RIM (22-17)	1	1			
	94307-19170	BAND, RIM (18-19)			1	1	
8	94414-17530	RIM (1.40-17)	1	1			
	94414-19521	RIM (1.40-19)			1	1	
9	4ES-25104-20	SPOKE SET, FRONT	1	1			
	4LB-25104-00	SPOKE SET, FRONT			1	1	
10	1T1-25194-00	SPACER, BEAD	1	1	1	1	
11	4ES-25181-00	AXLE, WHEEL	1	1	1	1	
12	90185-12010	NUT, SELF-LOCKING	1	1	1	1	
13	90201-12055	WASHER, PLATE	2	2	2	2	
14	4ES-25183-10	COLLAR, WHEEL	2	2	2	2	

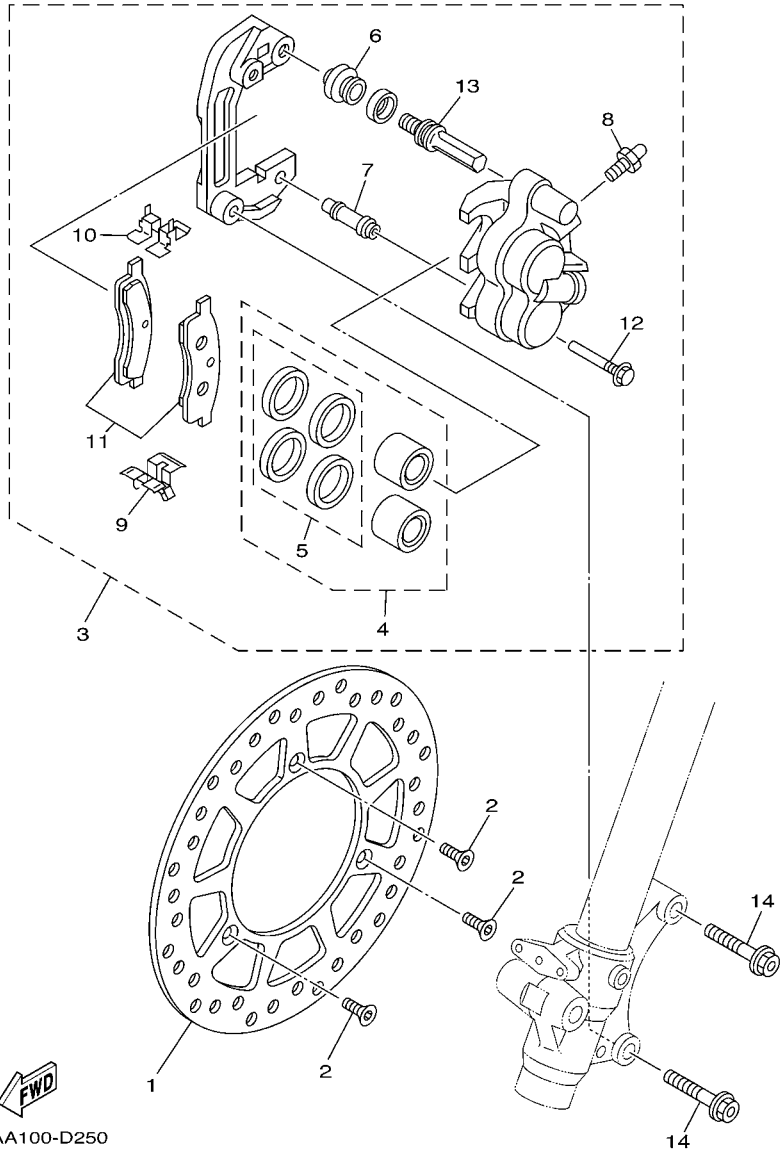
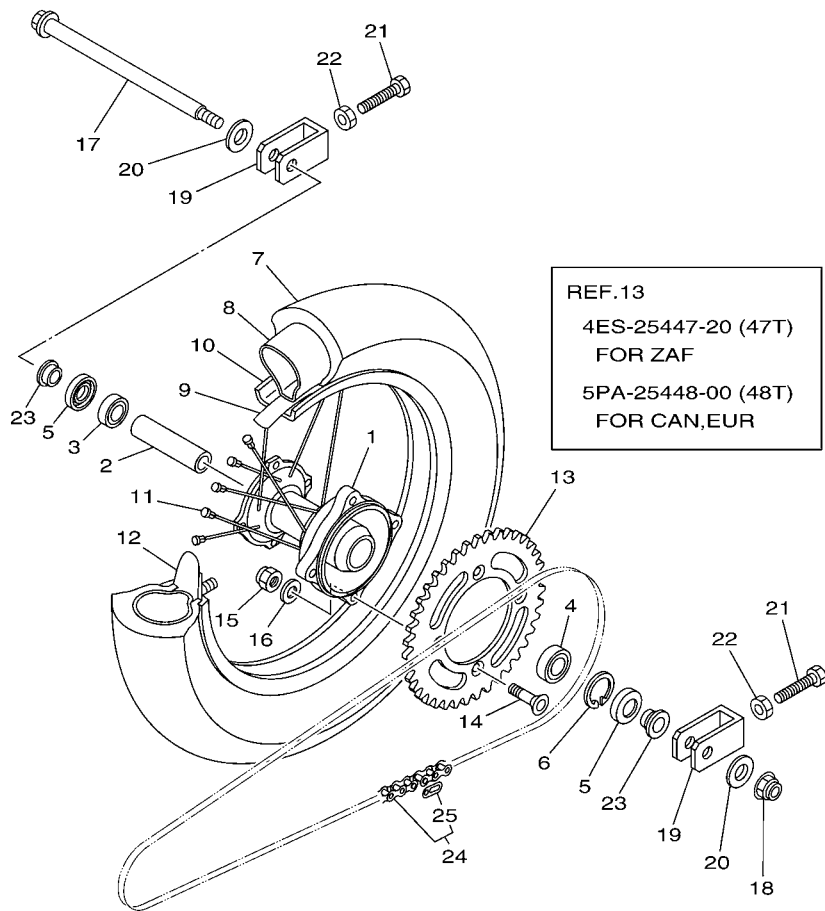

FIG. 25 FRONT BRAKE CALIPER

REF. NO.	PART NO.	DESCRIPTION	SPAN	SPAR	SSHN	SSHR	REMARKS
1	5PA-2582T-00	DISC, BRAKE (LEFT)	1	1	1	1	
2	90149-06327	SCREW	3	3	3	3	
3	5PA-2580T-00	CALIPER ASSY (LEFT)	1	1	1	1	
4	4ES-W0057-10	.PISTON ASSY, CALIPER	1	1	1	1	
5	4ES-W0047-10	..CALIPER SEAL KIT	1	1	1	1	
6	5R2-25937-00	.BOOT 2	1	1	1	1	
7	56A-25937-00	.BOOT 2	1	1	1	1	
8	51L-W0048-00	.BLEED SCREW KIT	1	1	1	1	
9	56A-25919-00	.SUPPORT, PAD	1	1	1	1	
10	56A-25919-10	.SUPPORT, PAD	1	1	1	1	
11	5PA-W0045-00	.BRAKE PAD KIT	1	1	1	1	
12	56A-25926-00	.BOLT	1	1	1	1	
13	34X-25914-00	.PIN, SLIDE	1	1	1	1	
14	90105-08211	BOLT, FLANGE	2	2	2	2	



5PAN100-H260

FIG. 26 REAR WHEEL

REF. NO.	PART NO.	DESCRIPTION	SPAN	SPAR	SSHN	SSHR	REMARKS
1	4ES-25311-00	HUB, REAR	1	1	1	1	
2	4ES-25383-00	COLLAR, WHEEL	1	1	1	1	
3	93306-00203	BEARING	1	1	1	1	
4	93306-20203	BEARING	1	1	1	1	
5	93102-20009	OIL SEAL	2	2	2	2	
6	99009-35500	CIRCLIP	1	1	1	1	
7	L.M.	TIRE (90/100-14 49M D756)	1				
	L.M.	TIRE (90/100-16 52M D756)			1		
8	L.M.	TUBE (80-90/100-14M/C TR4)	1				
	L.M.	TUBE (90/100-16M/C TR4)			1		
9	94308-14165	BAND, RIM (22-14)	1	1			
	94307-16171	BAND, RIM (18-16)			1	1	
10	94416-14529	RIM (1.60-14)	1	1			
	94418-16522	RIM (1.85-16)			1	1	
11	4ES-25304-20	SPOKE SET, REAR	1	1			
	4LB-25304-00	SPOKE SET, REAR			1	1	
12	5X2-25394-00	SPACER, BEAD	1	1			
	1T2-25394-00	SPACER, BEAD			1	1	
13	5PA-25448-00	SPROCKET, DRIVEN (48T)	1				UR STD
	4ES-25447-20	SPROCKET, DRIVEN (47T)	1	1			UR STD AFAM
	5PA-25446-00	SPROCKET, DRIVEN (46T)	1	1			AP
	5PA-25448-00	SPROCKET, DRIVEN (48T)	1				AP
	5PA-25449-00	SPROCKET, DRIVEN (49T)	1				AP
	5PA-25452-00	SPROCKET, DRIVEN (52T)			1	1	STD
	5PA-25451-00	SPROCKET, DRIVEN (51T)			1	1	AP

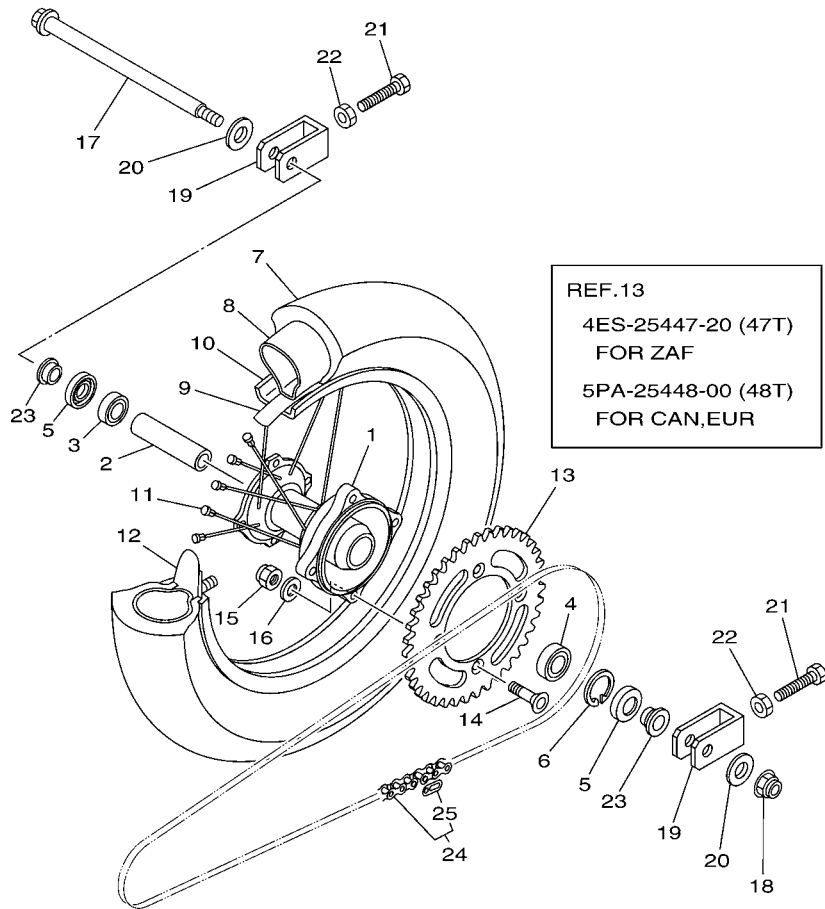

5PAN100-H260

FIG. 26 REAR WHEEL

REF. NO.	PART NO.	DESCRIPTION	SPAN	SPAR	SSHN	SSHR	REMARKS
13	5PA-25453-00	SPROCKET, DRIVEN (53T)			1	1	AP
14	90152-08001	SCREW, COUNTERSUNK	4	4	4	4	
15	90185-08008	NUT, SELF-LOCKING	4	4	4	4	
16	90201-08043	WASHER, PLATE	4	4	4	4	
17	4ES-25381-01	AXLE, WHEEL	1	1	1	1	
18	90185-14012	NUT, SELF-LOCKING	1	1	1	1	
19	5PA-25388-00	PULLER, CHAIN 1	2	2	2	2	
20	90201-15027	WASHER, PLATE	2	2	2	2	
21	90101-08060	BOLT	2	2	2	2	
22	95302-08700	NUT	2	2	2	2	
23	4ES-25383-10	COLLAR, WHEEL	2	2	2	2	
24	9Y582-00117	CHAIN (DID 428DS 118L)	1	1			
	9Y582-00123	CHAIN (DID 428DS 124L)			1	1	
25	94682-00001	.JOINT,CHAIN (DID 428DS-RJ)	1	1	1	1	

FIG. 27 REAR BRAKE CALIPER

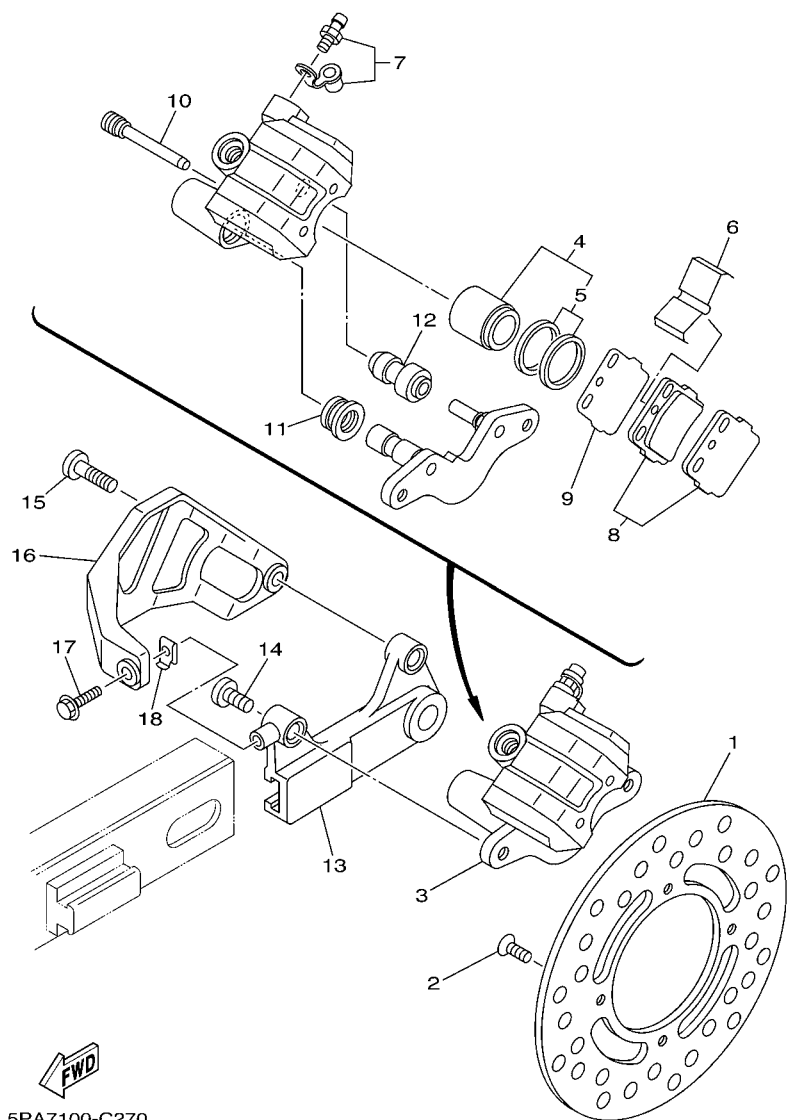

5PA7100-C270

REF. NO.	PART NO.	DESCRIPTION	SPAN	SPAR	SSHN	SSHR	REMARKS
1	5PA-2582W-00	DISK, REAR BRAKE 2	1	1	1	1	
2	90149-06327	SCREW	4	4	4	4	
3	5PA-2580W-00	CALIPER ASSY, REAR 2	1	1	1	1	
4	4EW-W0057-50	.PISTON ASSY, CALIPER	1	1	1	1	
5	4ES-W0047-00	..CALIPER SEAL KIT	1	1	1	1	
6	1UY-25919-51	..SUPPORT, PAD	1	1	1	1	
7	1UY-W0048-50	.BLEED SCREW KIT	1	1	1	1	
8	5PA-W0046-50	.BRAKE PAD KIT 2	1	1	1	1	
9	3GD-25827-00	.SHIM, CALIPER	1	1	1	1	
10	3GD-25933-00	.PIN, PAD	2	2	2	2	
11	1UY-25917-51	.BOOT, CALIPER	1	1	1	1	
12	1UY-25937-51	.BOOT 2	1	1	1	1	
13	4ES-25920-00	SUPT. BRKT. ASSY.	1	1	1	1	
14	90111-08029	BOLT,HEX. SOCKET BUTTON	1	1	1	1	
15	90109-08718	BOLT	1	1	1	1	
16	5PA-27491-00	PROTECTOR	1	1	1	1	
17	90105-06078	BOLT, FLANGE	1	1	1	1	
18	4ES-27114-00	STOPPER, MAIN STAND	1	1	1	1	

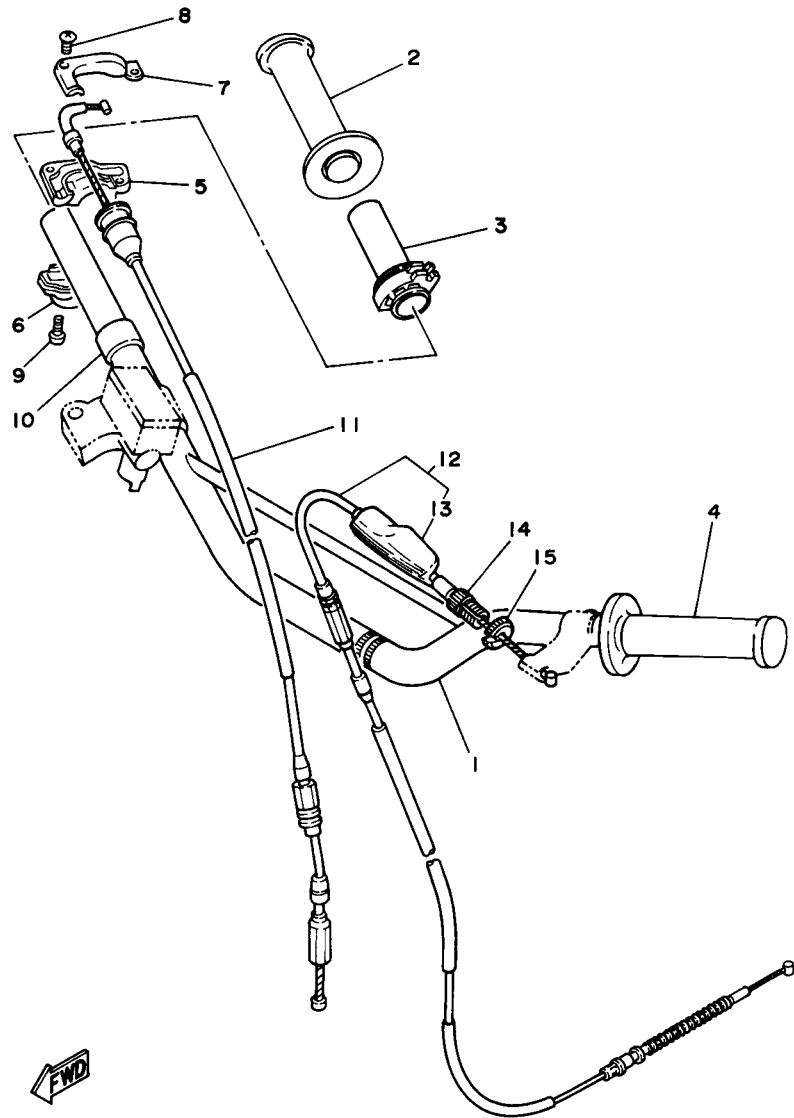

4ES6100-7280

FIG. 28 STEERING HANDLE & CABLE

REF. NO.	PART NO.	DESCRIPTION	SPAN	SPAR	SSHN	SSHR	REMARKS
1	5PA-26111-00	HANDLEBAR	1	1	1	1	
2	4GY-26242-00	GRIP (RIGHT)	1	1	1	1	
3	22W-26243-00	TUBE, THROTTLE GUIDE	1	1	1	1	
4	4GY-26241-00	GRIP	1	1	1	1	
5	5X2-26281-00	CAP, GRIP UPPER	1	1	1	1	
6	322-26282-00	CAP, GRIP UNDER	1	1	1	1	
7	5X2-2628H-01	CAP, WIRE	1	1	1	1	
8	98702-04012	SCREW, FLAT HEAD	2	2	2	2	
9	98502-05016	SCREW, PAN HEAD	2	2	2	2	
10	90387-227H7	COLLAR	1	1	1	1	
11	5PA-26311-00	CABLE, THROTTLE 1	1	1	1	1	
12	4ES-26335-11	CABLE, CLUTCH	1	1	1	1	
13	498-26372-00	.COVER, HANDLE LEVER 1	1	1	1	1	
14	90123-08046	BOLT	1	1	1	1	
15	90179-08148	NUT	1	1	1	1	

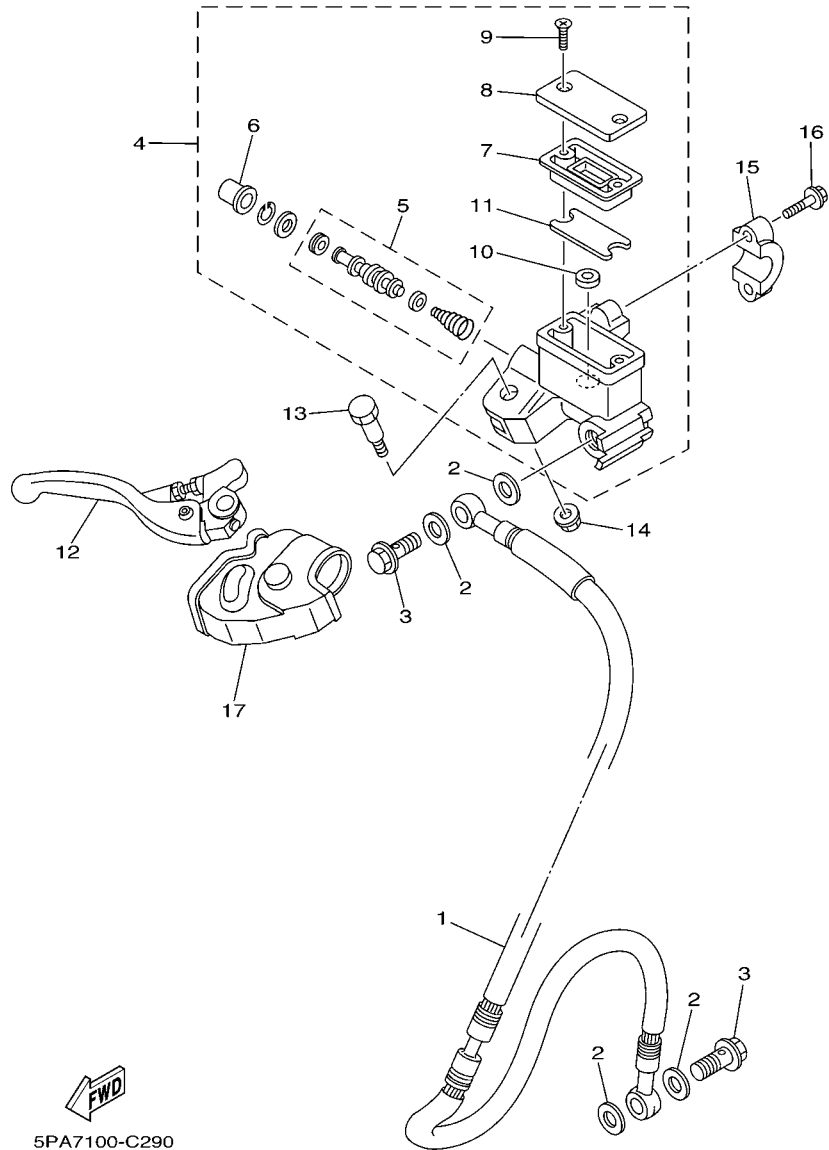
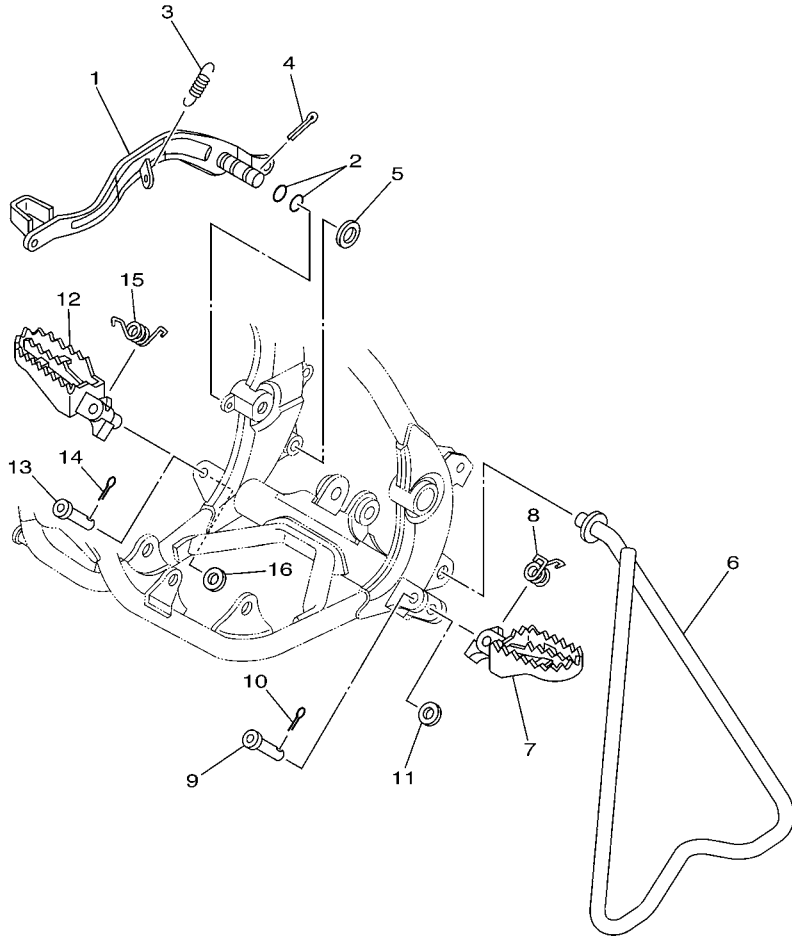

FIG. 29 FRONT MASTER CYLINDER

REF. NO.	PART NO.	DESCRIPTION	SPAN	SPAR	5SHN	5SHR	REMARKS
1	4ES-25872-11	HOSE, BRAKE 1	1	1			
	5SH-25872-01	HOSE, BRAKE 1			1	1	
2	90430-10005	GASKET	4	4	4	4	
3	90401-10168	BOLT, UNION	2	2	2	2	
4	5XE-W2587-00	MASTER CYLINDER SUB ASSY	1	1	1	1	
5	5NY-W0041-00	.CYLINDER KIT, MASTER	1	1	1	1	
6	5NY-25868-00	.BOOT, MASTER CYLINDER	1	1	1	1	
7	5XE-25854-00	.GASKET, DIAPHRAGM	1	1	1	1	
8	5MV-25852-01	.CAP, RESERVOIR	1	1	1	1	
9	98706-04012	.SCREW, FLAT HEAD	2	2	2	2	
10	5CG-25715-00	.SEPARATOR ASSY	1	1	1	1	
11	5XE-25853-00	.FLOAT, RESERVOIR	1	1	1	1	
12	5MV-83922-00	LEVER 2	1	1	1	1	
13	5MV-2589F-00	BOLT, LEVER	1	1	1	1	
14	95701-06500	NUT, WITH WASHER	1	1	1	1	
15	5MV-25867-00	BRACKET, MASTER CYLINDER	1	1	1	1	
16	5MV-25833-00	BOLT, FITTING	2	2	2	2	
17	5NY-26372-00	COVER, HANDLE LEVER 1	1	1	1	1	



5PA1100-A300

FIG. 30 STAND & FOOTREST

REF. NO.	PART NO.	DESCRIPTION	SPAN	SPAR	SSHN	SSHR	REMARKS
1	5PA-27211-00	PEDAL, BRAKE	1	1	1	1	
2	93210-11073	O-RING	2	2	2	2	
3	90506-15480	SPRING, TENSION	1	1	1	1	
4	91401-20025	PIN, COTTER	1	1	1	1	
5	90201-15700	WASHER, PLATE	1	1	1	1	
6	5PA-27311-00	STAND, SIDE	1	1			
	5SH-27311-00	STAND, SIDE			1	1	
7	5ET-27411-00	FOOTREST 1	1	1	1	1	
8	90508-282B8	SPRING, TORSION	1	1	1	1	
9	90240-10004	PIN, CLEVIS	1	1	1	1	
10	91401-25015	PIN, COTTER	1	1	1	1	
11	90201-10119	WASHER, PLATE	1	1	1	1	
12	5ET-27421-00	FOOTREST 2	1	1	1	1	
13	90240-10004	PIN, CLEVIS	1	1	1	1	
14	91401-25015	PIN, COTTER	1	1	1	1	
15	90508-282B9	SPRING, TORSION	1	1	1	1	
16	90201-10119	WASHER, PLATE	1	1	1	1	

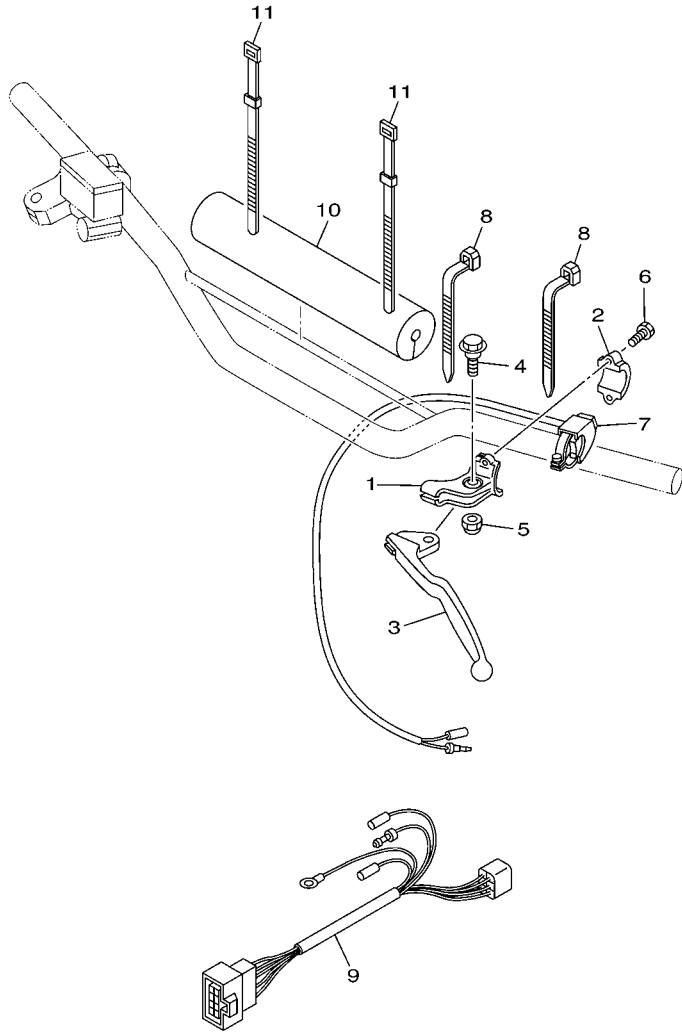

5PAA100-D330

FIG. 33 HANDLE SWITCH & LEVER

REF. NO.	PART NO.	DESCRIPTION	SPAN	SPAR	SSHN	SSHR	REMARKS
1	38V-82911-00	HOLDER, LEVER 1	1	1	1	1	
2	38V-82913-00	HOLDER, LEVER LOWER 1	1	1	1	1	
3	4GY-83912-00	LEVER 1	1	1	1	1	
4	90109-06799	BOLT	1	1	1	1	
5	95607-06100	NUT, U	1	1	1	1	
6	97007-05016	BOLT	2	2	2	2	
7	22W-83976-01	SWITCH, HANDLE 1	1	1	1	1	
8	90464-13077	CLAMP	2	2	2	2	
9	5PA-82509-00	WIRE, SUB LEAD	1	1	1	1	
10	2X1-26124-00	PROTECTOR, HANDLEBAR	1	1	1	1	
11	437-83936-11	BAND, SWITCH CORD	2	2	2	2	

NUMERICAL INDEX

PART NO.	REF. NO.	PART NO.	REF. NO.	PART NO.	REF. NO.	PART NO.	REF. NO.	PART NO.	REF. NO.	PART NO.	REF. NO.
5PA-11111-00	1 - 1	5PA-14392-00	6 - 7	5PA-15451-00	9 - 3	5PA-2118K-20	16 - 15	5PA-22210-80	19 - 1	4ES-23145-00	21 - 27
5PA-11311-10	1 - 8	5PA-14411-10	5 - 16	4ES-15461-00	9 - 5	5PA-21190-00-33	15 - 2	5PA-22210-90	19 - 1	5K5-23149-00	21 - 6
4ES-11351-00	1 - 9	5PA-14417-00	5 - 22	5PA-15463-00	9 - 14	5PA-21274-10	15 - 15	4ES-22212-F0	19 - 6		21 - 26
5PA-11400-00	2 - 1	5PA-14451-00	5 - 17	5PA-15620-01	10 - 11	4ES-21511-20	16 - 1		35 - 1	5PA-23149-00	21 - 16
5PA-11412-00	2 - 2	5PA-14453-00	5 - 10	5PA-15621-00	10 - 12	4LB-2151H-02	16 - 16	4ES-22212-G0	19 - 6		21 - 36
5PA-11422-00	2 - 3	5PA-14458-00	5 - 18	5PA-15641-00	10 - 2	3XJ-2151H-A1	16 - 16		35 - 1	4ES-2314F-00	21 - 44
5PA-11611-00	2 - 10	5PA-14459-00	5 - 11	5PA-15651-00	10 - 8	3XJ-2151H-B1	16 - 20	4ES-22212-H0	19 - 6	5PA-2314H-L0	21 - 46
	36 - 3	4ES-14462-00	5 - 12	5PA-15660-00	10 - 1	4XL-2153A-10	21 - 49		35 - 1	5PA-2314J-L0	21 - 47
5PA-11630-00	36 - 1	676-14548-00	6 - 20	4ES-15664-00	10 - 6		21 - 50	4ES-22212-J0	35 - 1	4A1-23156-00	21 - 8
5PA-11631-00-A0	2 - 8	4MX-14561-00	6 - 6	5PA-16111-00	11 - 1	4ES-2153E-01	16 - 5	4ES-22212-K0	19 - 6		21 - 28
5PA-11631-00-B0	2 - 8	5PA-14610-00	7 - 1	5PA-16150-10	11 - 6		16 - 17		35 - 1	2HH-23158-L0	21 - 12
	36 - 2	17W-14615-00	7 - 18	5PA-16181-00	11 - 23	5PA-21568-01	16 - 15	4ES-22212-M0	35 - 1		21 - 32
5PA-11631-00-C0	2 - 8	5PA-14642-00	7 - 7	21V-16321-00	11 - 12	5PA-21611-00	16 - 8	3JD-22214-00	19 - 8	5PA-2316A-00	21 - 11
5PA-11631-00-D0	2 - 8	4ES-1469A-00	7 - 12	4ES-16321-00	11 - 11	4ES-21642-00	16 - 13	4ES-22214-00	19 - 7		21 - 31
4ES-11633-00	2 - 9	5PA-1469A-00	7 - 12	131-16324-00	11 - 10	3RV-21668-A0	18 - 44	4ES-22216-00	19 - 3	5SH-2316A-00	21 - 11
	36 - 4	5PA-14753-00	7 - 11	2TK-16351-00	11 - 9	3RV-21668-B0	18 - 45	4ES-22251-00	19 - 9		21 - 31
4ES-11650-10	36 - 6	4ES-14753-20	7 - 11	4ES-16356-00	11 - 17	5PA-21711-00	17 - 1	5PA-22253-00	18 - 34	5PA-23170-00	21 - 10
4ES-11651-10	2 - 4	565-14771-00	7 - 9	5PA-16357-00	11 - 18	5PA-21721-00	17 - 6	4AA-22259-40	19 - 5		21 - 30
	36 - 7	5PA-14916-KE	6 - 9	5PA-16371-10	11 - 8	5PH-2172A-20	17 - 14	4AA-22259-50	19 - 5	5PA-23171-00	21 - 4
2RA-11681-00	2 - 6	5PA-14916-KF	6 - 9	4ES-16381-00	11 - 22	5PA-21731-10	17 - 9	4AA-22259-60	19 - 5		21 - 24
	36 - 9	5PA-14916-KG	6 - 9	4ES-17121-01	12 - 5	5PA-2173E-30	17 - 2	5PA-22475-00	18 - 32	58T-23184-L0	19 - 4
4BA-12422-00	3 - 9	5PA-14916-LE	6 - 9	4ES-17131-03	12 - 3	5PA-2173F-30	17 - 3	5PA-23102-10	21 - 1	4V4-23188-L0	21 - 18
4BA-12428-00	3 - 10	5PA-14916-LF	6 - 9	4ES-17151-10	12 - 2	1FK-21746-00	17 - 13	5SH-23102-10	21 - 1		21 - 38
5PA-12451-00	3 - 4	5PA-14916-LG	6 - 9	4ES-17161-10	12 - 4	5PA-22110-00	18 - 1	5PA-23103-10	21 - 21	4V4-23194-L0	21 - 45
5PA-12459-00	3 - 1	4MX-14919-00	6 - 10	4ES-17211-01	12 - 17	5SH-22110-10	18 - 1	5SH-23103-10	21 - 21	5PA-23318-00	21 - 51
5PA-12461-00	4 - 1	5HC-14922-00	6 - 23	5PA-17221-00	12 - 12	5PA-22128-00	18 - 15	5PA-23110-00	21 - 23	5PA-2331E-10	21 - 43
22W-12462-00	4 - 2	5HC-14934-00	6 - 24	4ES-17231-10	12 - 14	4ES-22129-00	18 - 23	4ES-23111-10	21 - 17	5PA-23340-01	21 - 41
22W-12463-00	4 - 3	4MX-14943-34	6 - 22	5PA-17241-00	12 - 15	5PA-22151-00	18 - 11		21 - 37	5PA-23346-00	21 - 42
4ES-12481-10	4 - 5	4MX-14943-35	6 - 22	4ES-17251-00	12 - 16	5PA-22176-00	18 - 31	5PA-23120-00	21 - 3	3XJ-23357-L0	21 - 14
5PA-12482-00	4 - 7	4MX-14943-36	6 - 22	5PA-17261-00	12 - 13	30X-22178-00	15 - 8	5PA-23125-00	21 - 5		21 - 34
353-13115-01	8 - 8	4MX-14943-84	6 - 22	5PA-17411-00	12 - 1	4ES-22178-00	15 - 12		21 - 25	4DA-23389-00	20 - 4
5PA-13565-00	5 - 6	4MX-14943-85	6 - 22	5PA-17421-00	12 - 11	5PA-2217A-00	18 - 20	3JD-2312G-L0	21 - 20	3JD-23394-00	21 - 19
4ES-13610-00	5 - 1	4MX-14943-86	6 - 22	164-17427-00-06	12 - 21	4ES-2217F-00	18 - 35		21 - 40		21 - 39
4ES-13613-00	5 - 2	4MX-14943-87	6 - 22	164-17427-00-08	12 - 21	4V4-22184-00	15 - 9	5PA-23136-10	21 - 2	1J7-23415-00	20 - 3
4ES-13616-00	5 - 3	5PA-14947-00	6 - 30	164-17427-00-10	12 - 21	5PA-22184-00	18 - 33		21 - 22	4ES-23435-00	20 - 9
5PA-14101-00	6 - 1	4MX-14948-04	6 - 8	5PA-18101-00	14 - 1	5PA-22199-00	18 - 14	4LB-23141-10	21 - 15	3SP-23441-00	20 - 11
5PA-14105-00	6 - 13	4MX-14948-05	6 - 8	2HF-18110-02	14 - 9	5SH-22201-30	19 - 2		21 - 35	4ES-23485-00	20 - 13
5PA-1410E-00	6 - 18	4MX-14948-06	6 - 8	5PA-1811E-00	14 - 6	5SH-22201-40	19 - 2	4ES-23141-40	21 - 15	5PA-24110-30	22 - 1
4MX-14115-00	6 - 5	5PA-18140-00	6 - 29	5PA-18140-00	14 - 7	5SH-22201-50	19 - 2		21 - 35	4EW-2412F-00	22 - 7
5PA-14126-00	6 - 12	5PA-14984-00	6 - 4	4ES-18511-02	13 - 2	5PA-22201-60	19 - 2		35 - 2	3HA-24141-00	15 - 17
5PA-14131-00	6 - 14	5PA-14985-00	6 - 3	5R2-18512-00	13 - 3	5PA-22201-70	19 - 2	4ES-23141-50	35 - 2	5XE-24144-00	22 - 2
3TJ-14137-40	6 - 21	5PA-15111-00	8 - 1	4ES-18513-01	13 - 4	5PA-22201-80	19 - 2	4ES-23141-60	35 - 2	3ME-2415E-01	16 - 18
5PA-14146-00	6 - 28	5PA-15118-00	8 - 10	4BA-18531-00	13 - 6	5PA-22201-90	19 - 2	4ES-23141-70	35 - 2	3XJ-2415E-A1	16 - 4
5PA-14159-00	6 - 15	5PA-15121-10	8 - 2	4BA-18535-00	13 - 7	5SH-22210-30	19 - 1	4ES-23142-00	21 - 13	3XJ-2415E-B1	16 - 6
4JT-14171-00	6 - 2	3Y1-15363-00	9 - 11	4ES-18540-00	13 - 1	5SH-22210-40	19 - 1		21 - 33	3XJ-2415E-C1	16 - 4
5PA-14194-00	6 - 25	4ES-15411-00	9 - 1	5PA-21101-12-33	15 - 1	5SH-22210-50	19 - 1	4ES-23144-00	21 - 9	4SR-2416E-00	16 - 7
4XL-14197-10	6 - 19	5PA-15415-10	9 - 13	5PA-2118K-00	16 - 15	5PA-22210-60	19 - 1		21 - 29	5PA-24181-00	22 - 26
5PA-14340-00	6 - 11	5PA-15431-00	9 - 4	5PA-2118K-10	16 - 19	5PA-22210-70	19 - 1	4ES-23145-00	21 - 7	5PA-24182-00	22 - 20

NUMERICAL INDEX

PART NO.	REF. NO.	PART NO.	REF. NO.	PART NO.	REF. NO.	PART NO.	REF. NO.	PART NO.	REF. NO.	PART NO.	REF. NO.
5PA-24230-10	17 - 10	5XE-25853-00	29 - 11	5PA-82509-00	33 - 9	90119-06217	7 - 10	90201-12047	18 - 41	90387-127J7	18 - 8
5PA-24240-70	22 - 22	2VN-25854-00	31 - 12	38V-82911-00	33 - 1		17 - 5	90201-12049	18 - 42	90387-127J8	18 - 7
5PA-24311-00	22 - 23	5XE-25854-00	29 - 7	38V-82913-00	33 - 2		17 - 8	90201-12055	24 - 13	90387-202A0	12 - 29
3XJ-24380-00	22 - 11	2VN-25855-00	31 - 13	4GY-83912-00	33 - 3	90119-06239	16 - 14	90201-124F8	10 - 9	90387-20488	11 - 2
4DP-24500-01	22 - 13	2VN-25866-00	31 - 4	5MV-83922-00	29 - 12	90119-06240	17 - 4	90201-15027	26 - 20	90387-227H7	28 - 10
4X8-24512-00	22 - 16	5MV-25867-00	29 - 15	437-83936-11	33 - 11		17 - 7	90201-15700	30 - 5	90401-10168	29 - 3
3AC-24523-00	22 - 17	5NY-25868-00	29 - 6	22W-83976-01	33 - 7	90122-06010	5 - 20	90201-171G6	11 - 24		31 - 20
3AJ-24534-01	22 - 14	5SH-25872-01	29 - 1	5PA-85540-00	34 - 1	90123-08046	28 - 14	90201-17545	12 - 8	90430-06166	3 - 11
5NY-24610-00	22 - 9	4ES-25872-11	29 - 1	5PA-85546-00	34 - 2	90149-06108	22 - 19	90201-17558	11 - 7	90430-08119	9 - 10
5PA-2470F-10	23 - 2	5PA-25873-01	31 - 19	4SS-85550-11	32 - 2		32 - 3	90201-176L4	10 - 4	90430-10005	29 - 2
5PA-24718-00	23 - 3	5SH-25873-01	31 - 19	5PA-85560-01	32 - 1	90149-06327	25 - 2	90201-177G4	14 - 5		31 - 21
5PA-24728-00	23 - 4	2VM-25876-00	31 - 22	5NY-W0041-00	29 - 5		27 - 2	90201-20611	12 - 20	90445-08376	8 - 9
5PA-24770-20	23 - 1	4EW-25894-00	31 - 10	1FK-W0042-50	31 - 2	90151-06045	10 - 15	90201-22070	20 - 8	90445-09220	22 - 10
4LB-25104-00	24 - 9	4ES-25895-00	31 - 8	5PA-W0045-00	25 - 11	90152-08001	26 - 14	90201-256K5	20 - 2	90445-09300	22 - 12
4ES-25104-20	24 - 9	5MV-2589F-00	29 - 13	5PA-W0046-50	27 - 8	90157-05029	20 - 5	90201-33299	7 - 2	90450-25037	4 - 6
4ES-25111-00	24 - 1	34X-25914-00	25 - 13	4ES-W0047-00	27 - 5	90157-06008	12 - 10	90202-05193	22 - 18	90450-28014	4 - 8
4ES-25181-00	24 - 11	1UY-25917-51	27 - 11	4ES-W0047-10	25 - 5	90159-06021	17 - 12	90208-12015	11 - 4	90450-41001	5 - 8
22W-25181-01	18 - 2	56A-25919-00	25 - 9	51L-W0048-00	25 - 8	90159-06182	17 - 11		11 - 15	90450-99064	5 - 15
4ES-25183-10	24 - 14	56A-25919-10	25 - 10	1UY-W0048-50	27 - 7	90176-08005	1 - 6	90209-06015	16 - 3	90460-15126	34 - 3
1T1-25194-00	24 - 10	1UY-25919-51	27 - 6	4ES-W0057-10	25 - 4	90179-08019	1 - 13	90209-06096	5 - 19	90460-56071	5 - 9
4LB-25304-00	26 - 11	4ES-25920-00	27 - 13	4EW-W0057-50	27 - 4	90179-08148	28 - 15	90209-14008	12 - 7	90461-10136	8 - 12
4ES-25304-20	26 - 11	56A-25926-00	25 - 12	5XE-W2587-00	29 - 4	90179-12007	11 - 5	90209-16209	12 - 18	90464-13077	4 - 12
4ES-25311-00	26 - 1	3GD-25933-00	27 - 10	90101-08060	26 - 21		11 - 16	90209-20159	2 - 7		33 - 8
4ES-25381-01	26 - 17	56A-25937-00	25 - 7	90101-12755	18 - 39	90179-16226	12 - 31		36 - 10	90464-25004	32 - 6
4ES-25383-00	26 - 2	5R2-25937-00	25 - 6	90105-06078	27 - 17	90179-22025	20 - 7	90215-20261	12 - 30	90465-13275	22 - 21
4ES-25383-10	26 - 23	1UY-25937-51	27 - 12	90105-06180	34 - 5	90179-25002	20 - 6	90240-08124	31 - 14	90467-08002	4 - 4
5PA-25388-00	26 - 19	5PA-26111-00	28 - 1	90105-08126	8 - 11	90183-060A7	16 - 12	90240-10004	30 - 9	90467-09002	22 - 25
1T2-25394-00	26 - 12	2X1-26124-00	33 - 10	90105-08211	25 - 14	90185-08008	26 - 15		30 - 13	90467-10008	22 - 24
5X2-25394-00	26 - 12	4GY-26241-00	28 - 4	90105-10219	15 - 6	90185-10018	19 - 12	90250-06013	13 - 5	90467-11044	31 - 9
5PA-25446-00	26 - 13	4GY-26242-00	28 - 2	90105-10220	15 - 5	90185-12010	24 - 12	90267-48138	5 - 13	90468-23194	10 - 3
4ES-25447-20	26 - 13	22W-26243-00	28 - 3	90105-10582	18 - 24	90185-12011	18 - 40	90280-03017	2 - 13	90480-15528	4 - 10
5PA-25448-00	26 - 13	5X2-26281-00	28 - 5	90105-10614	19 - 13	90185-14012	26 - 18	90282-05001	11 - 3	90480-16561	7 - 15
	26 - 13	322-26282-00	28 - 6	90109-065F3	5 - 21	90201-043H7	5 - 14	90336-06031	10 - 17	90480-18411	7 - 3
5PA-25449-00	26 - 13	5X2-2628H-01	28 - 7	90109-06799	33 - 4	90201-06060	10 - 19	90338-10150	18 - 43	90480-18549	22 - 4
5PA-25451-00	26 - 13	5PA-26311-00	28 - 11	90109-08718	27 - 15		12 - 9	90380-10218	18 - 22	90501-12081	10 - 13
5PA-25452-00	26 - 13	4ES-26335-11	28 - 12	90109-10729	19 - 10	90201-06086	7 - 5	90380-12219	18 - 28	90501-204A0	11 - 13
5PA-25453-00	26 - 13	498-26372-00	28 - 13	90109-12015	18 - 29	90201-06089	7 - 14	90381-12091	18 - 38	90506-15480	30 - 3
5CG-25715-00	29 - 10	5NY-26372-00	29 - 17	90111-08029	15 - 3	90201-08043	26 - 16	90385-17042	18 - 5	90507-20052	7 - 8
5PA-2580T-00	25 - 3	4ES-27114-00	27 - 18		27 - 14	90201-08078	15 - 10	90387-06027	22 - 5	90508-14016	11 - 25
5PA-2580W-00	27 - 3	5PA-27211-00	30 - 1	90116-08027	1 - 5	90201-08083	31 - 15	90387-0614M	4 - 11	90508-24007	14 - 3
3GD-25827-00	27 - 9	2YK-27222-00	31 - 6	90116-08028	1 - 11	90201-080L8	1 - 7	90387-06168	7 - 16	90508-26750	10 - 5
2VN-2582A-50	31 - 5	5PA-27311-00	30 - 6	90116-08031	1 - 10	90201-08512	3 - 2	90387-06180	18 - 13	90508-282B8	30 - 8
5PA-2582T-00	25 - 1	5SH-27311-00	30 - 6	90119-05001	11 - 14		3 - 5	90387-064X4	16 - 10	90508-282B9	30 - 15
5PA-2582W-00	27 - 1	5ET-27411-00	30 - 7	90119-06133	16 - 9	90201-10119	30 - 11	90387-067K6	15 - 14	90508-32016	14 - 2
5MV-25833-00	29 - 16	5ET-27421-00	30 - 12	90119-06159	15 - 13		30 - 16	90387-0701A	16 - 11	91401-16012	31 - 16
4ES-2583V-00	31 - 1	5PA-27491-00	27 - 16	90119-06181	4 - 9	90201-10591	32 - 5	90387-105L0	7 - 4	91401-20025	30 - 4
5MV-25852-01	29 - 8	5PA-82310-00	34 - 4	90119-06190	22 - 6	90201-11016	19 - 14	90387-1200U	18 - 9	91401-25015	30 - 10
3XP-25852-50	31 - 11	8DG-82370-00	34 - 6	90119-06201	16 - 2	90201-12032	18 - 4	90387-124H0	24 - 2		30 - 14

NUMERICAL INDEX

PART NO.	REF. NO.	PART NO.	REF. NO.	PART NO.	REF. NO.	PART NO.	REF. NO.	PART NO.	REF. NO.	PART NO.	REF. NO.
92012-06010	7 - 13	93440-17064	12 - 6	95022-08080	9 - 9						
92012-06040	18 - 16	93450-16115	2 - 11	95024-06010	21 - 48						
92902-03100	5 - 5		36 - 5	95027-06012	23 - 5						
92902-10600	19 - 11	93503-16003	11 - 19	95027-06016	22 - 3						
92903-04600	6 - 17	93507-32009	10 - 14	95302-08700	26 - 22						
	6 - 27	9382A-14227	12 - 28	95307-08600	31 - 7						
93101-12173	14 - 8	9382A-15228	12 - 28	95312-10600	32 - 4						
93101-17062	18 - 27	94107-17012	24 - 5	95602-06200	18 - 17						
	18 - 37	94107-17019	24 - 5	95602-08200	18 - 19						
93102-12106	3 - 7	94107-19012	24 - 5	95602-10200	15 - 7						
93102-12224	11 - 21	94107-19015	24 - 5		18 - 25						
93102-17263	10 - 7	94109-14012	26 - 7	95602-12200	18 - 30						
93102-20009	26 - 5	94109-14015	26 - 7	95607-06100	33 - 5						
93102-20447	2 - 17	94109-16012	26 - 7	95612-12100	18 - 3						
93102-26042	12 - 27	94109-16015	26 - 7	95701-06500	29 - 14						
93102-28009	2 - 16	94207-17284	24 - 6	95802-08035	20 - 10						
93106-20031	24 - 4	94207-19290	24 - 6	95812-08125	15 - 4						
93109-11073	3 - 6	94208-14285	26 - 8	95822-06010	4 - 13						
93109-17071	18 - 10	94209-16291	26 - 8	95822-06060	3 - 12						
93210-11073	30 - 2	94307-16171	26 - 9	97007-05016	33 - 6						
93210-12152	10 - 16	94307-17166	24 - 7	97022-06020	14 - 10						
93210-15620	31 - 3	94307-19170	24 - 7	98502-03006	5 - 4						
93210-19123	9 - 12	94308-14165	26 - 9	98502-05010	31 - 23						
93210-56459	1 - 3	94414-17530	24 - 8	98502-05016	28 - 9						
93210-84724	1 - 4	94414-19521	24 - 8	98502-06030	9 - 2						
93306-00105	3 - 8	94416-14529	26 - 10	98502-06040	8 - 4						
93306-00203	26 - 3	94418-16522	26 - 10	98502-06050	8 - 5						
93306-20120	24 - 3	94682-00001	26 - 25	98502-06060	8 - 6						
93306-20203	26 - 4	94702-00368	1 - 2	98502-06070	8 - 7						
93306-20333	12 - 23	94709-00368	1 - 2	98504-04012	6 - 26						
93306-20401	12 - 26	95022-06012	10 - 18	98504-04014	6 - 16						
93306-20438	2 - 14		15 - 16	98507-03008	22 - 15						
93306-30421	2 - 15		20 - 14	98702-04012	28 - 8						
93310-21417	2 - 12		31 - 18	98702-06025	22 - 8						
	36 - 11	95022-06014	18 - 12	98706-04012	29 - 9						
93310-420B1	2 - 5	95022-06016	31 - 17	99009-10400	13 - 8						
	36 - 8	95022-06020	5 - 7	99009-12400	10 - 10						
93315-11206	11 - 20		21 - 52	99009-17400	14 - 4						
93315-21455	18 - 21	95022-06025	3 - 13	99009-35500	26 - 6						
93315-31502	12 - 25		7 - 6	99530-08016	9 - 15						
93317-11245	12 - 24		7 - 17	99530-10014	8 - 3						
93317-21746	18 - 6		9 - 16		9 - 6						
93317-31771	18 - 26	95022-06030	9 - 7	99590-10114	1 - 12						
	18 - 36	95022-06035	9 - 17	9Y582-00117	26 - 24						
93332-00079	20 - 1	95022-06040	9 - 8	9Y582-00123	26 - 24						
93410-20038	12 - 19	95022-08012	15 - 11								
93440-07182	3 - 3	95022-08030	20 - 12								
93440-15012	12 - 22	95022-08050	18 - 18								